

SB-ITC

Reference Guide

© March 2011 CompuLab

All Rights Reserved. No part of this document may be photocopied, reproduced, stored in a retrieval system, or transmitted, in any form or by any means whether, electronic, mechanical, or otherwise without the prior written permission of CompuLab.

No warranty of accuracy is given concerning the contents of the information contained in this publication. To the extent permitted by law no liability (including liability to any person by reason of negligence) will be accepted by CompuLab, its subsidiaries or employees for any direct or indirect loss or damage caused by omissions from or inaccuracies in this document.

CompuLab reserves the right to change details in this publication without notice.

Product and company names herein may be the trademarks of their respective owners.

CompuLab
P.O. Box 66 Neshar
36770 ISRAEL
Tel: +972 (4) 8290100
<http://www.compulab.co.il>
Fax: +972 (4) 8325251

Table of Contents

1	INTRODUCTION	1
1.1	About This Document.....	1
1.2	Related Documents.....	1
2	OVERVIEW.....	2
2.1	Highlights	2
2.2	Block Diagram.....	3
2.3	Features.....	4
3	SYSTEM COMPONENTS	6
3.1	PCIe Mux.....	6
3.2	PCIe to PCI Bridge	6
3.3	Audio Codec	7
3.4	LCD Power Switch.....	7
3.5	Analog VGA.....	7
3.6	Video Extension Slot	8
3.7	DC Power Supply	8
4	SB-ITC CONNECTOR DESCRIPTION	10
4.1	COM1 Connector (P40B).....	10
4.2	COM2, COM3, COM4 Connectors (P41, P1163, P1060).....	10
4.3	RS485 Connector (P1159).....	11
4.4	USB Host Connectors (P3B, P4B, U6).....	11
4.5	USB Device Connector (P1033).....	11
4.6	GPIO, Misc Header (P50).....	12
4.7	SATA Connectors (P35, P1058).....	12
4.8	SDIO Connector (P34).....	13
4.9	Audio Interface (P21, P22, P23, P24, P25, P26, P27, P28, P29, P30, P31, P32, U9, E12, E13, E14).....	13
	4.9.1 CM-iTC Audio.....	13
	4.9.2 Base-board Audio	16
4.10	VGA CONNECTOR (P40A).....	17
4.11	LCD Panel 18-bit Connector (P39).....	18
4.12	LCD Panel 24-bit Connector (P38).....	18
4.13	LVDS Panel Connector (P37).....	19
4.14	PCI Slot (P51).....	19
4.15	PCIe Slot (P44)	21
4.16	SDVO Extension Slot (P42)	21
4.17	Gigabit Ethernet (P4A & P3A).....	22
4.18	Power Connector (J1, P11, P43, P54).....	23
5	MECHANICAL DRAWINGS.....	24
5.1	Connector Locations	24
5.2	Default Jumper Settings.....	25
5.3	SB-iTC jumpers and connectors	26
6	OPERATIONAL CHARACTERISTICS	27
6.1	Power Output Specifications.....	27
6.2	Operating Temperature Ranges	27

Table 1 Document Revision Notes

Date	Description
30-Mar-2011	<ul style="list-style-type: none">• First release
13-Nov-2011	<ul style="list-style-type: none">• Corrected some inaccuracies in the pinout tables• Added paragraph 5.3 "SB-iTC jumpers and connectors"

Please check for a newer revision of this manual at CompuLab's web site – <http://www.compulab.co.il/>. Compare the revision notes of the updated manual from the web site to those of the printed or electronic version you have.

1 Introduction

1.1 About This Document

This document is part of a set of reference documents providing information necessary to operate and program the CompuLab SB-iTC.

1.2 Related Documents

For additional information not covered in this manual, please refer to the documents listed in Table 2.

Table 2 Related Documents

Document	Location
CM-iTC Reference Guide	http://www.compulab.co.il/

2 Overview

2.1 Highlights

<ul style="list-style-type: none"> • mini-ATX PC implemented by the combination of a CM-iTC module and SB-iTC baseboard • Intel Atom E680 (Tunnel Creek) CPU @ 1.6GHz and EG20T chipset • Up to 2 GB DDR2 • 8-23 GB microSD Flash Disk • UXGA graphics controller with interfaces for LVDS, RGB, DVI and HDMI panels • Two SATA hard disk interfaces • 2 x 1000 BaseT Ethernet ports • 6 USB host ports and device port • SDIO socket • Two HD Sound codecs with support for 5.1 HD audio and 2W external speakers • Host USB ports, including keyboard & mouse support • PCI and PCI-express extension buses • Serial ports, GPIO, I2C, SPI & CANbus • Programmable watchdog timer • IEEE1588 device support • 7 - 20 volt supply, 4 - 9 watt 	<p>The SBC-iTC is single board computer with mini-ATX form factor. It is implemented by a CM-iTC module providing most of the functions, and a SB-iTC carrier board providing connectors and several additional functions. The rich feature set of the SBC-iTC is customizable according to the price / performance targets of the user's application.</p> <p>The SBC-iTC contains expansion connectors which open it to the wide range of standard peripheral cards. Wide input range switched power supply is compatible with requirements for telecom and automotive applications.</p>
--	---

2.2 Block Diagram

Figure 1 SB-iTC Block Diagram

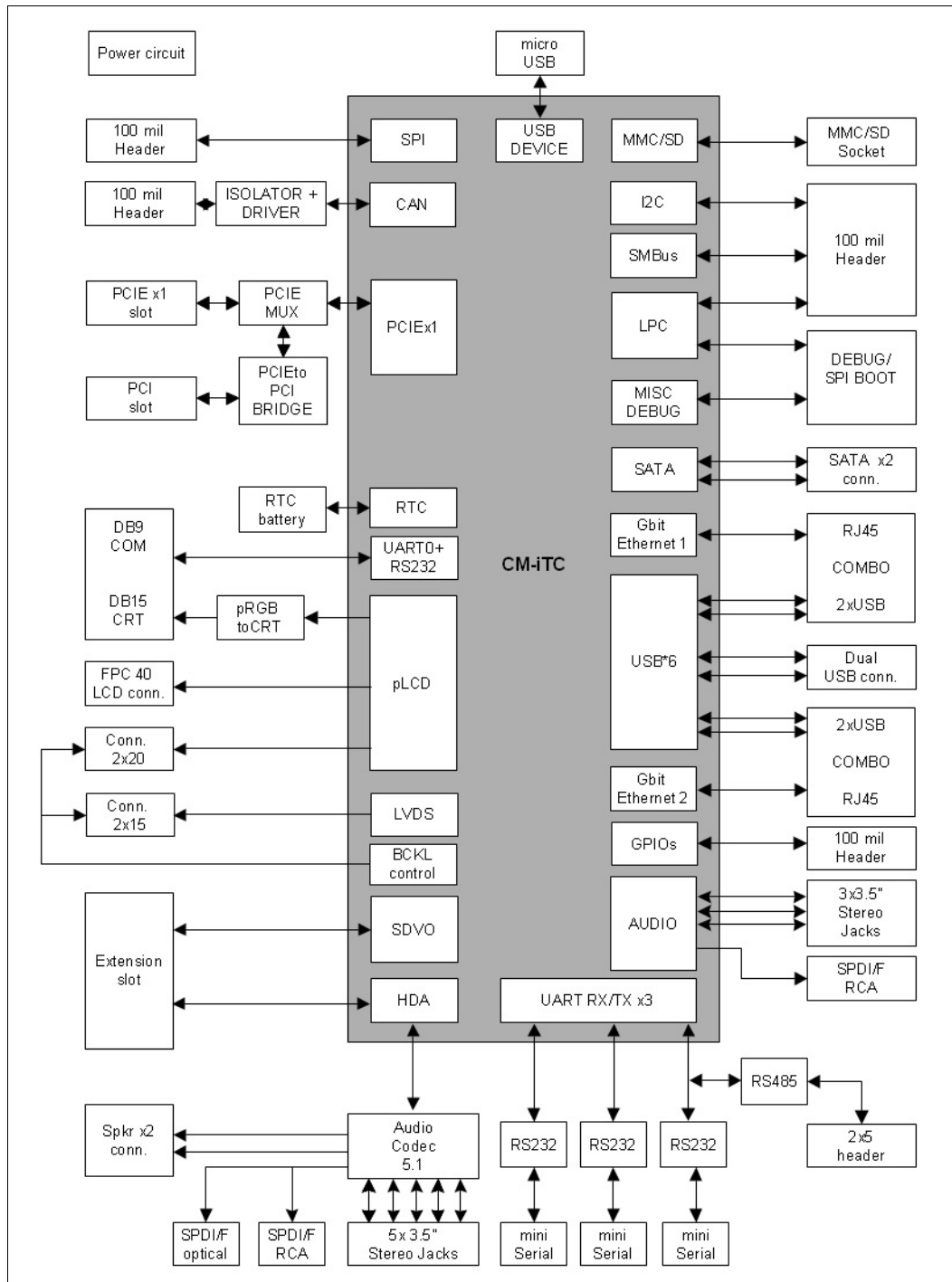

2.3 Features

The SB-iTC feature set is the combination of functionality provided by the attached CM-iTC and the functionality implemented on the SB-iTC itself. In order for SB-iTC to provide a particular feature, both the CM and SB options of that feature must be implemented.

Table Legend:

SB Option column	P/N code of SB-iTC required for the particular feature
CM Option column	P/N code of CM-iTC required for the particular feature
+	Indicates that the feature is always available, regardless of P/N code

Table 3 SB-iTC Features

Feature	Specifications	SB Option	CM Option
CPU SDRAM Flash Disk	See the Feature List section in <i>CM-iTC</i> module		
UART's	COM0 - full modem controls, RS-232 levels, DB9 connector COM1 - Rx/Tx only, RS-232/RS485 levels, mini serial connector COM2 - Rx/Tx only, RS-232 levels, mini serial connector COM3 - Rx/Tx only, RS-232 levels, mini serial connector	+	+
Hard Disk	2 SATA interfaces, on 7-pin vertical SATA connector	+	+
Ethernet	One or two 1000 Mb Ethernet ports, using Realtek RTL8111 provided by CM-iTC CoM. RJ-45 connectors and activity LED's are provided on SB card	+	Ex
TFT Panel	TFT (digital RGB) Panel Interface - 18-bit and 24-bit. Two connectors for direct interfacing to certain TFT panels	+	L
LVDS Panel	4-pair LVDS panel interface	+	+
CRT Monitor	Analog RGB interface for CRT and FP monitors, through an HDB15 connector	M	+
CAN bus	CAN bus interface with isolator and driver, on 100-mil header	+	+
Host USB	6 USB Host ports, 480 Mbps. Type-A connectors	+	+
Sound I/O	One or two audio codecs: ALC662 codec on module, headphone / speakers output line in / microphone in / SPDIF with coaxial interface 92HD83 Codec on baseboard, 5.1 speaker output, SPDIF with optical interface and coaxial interfaces	+	A
PCI-Express Extension	Standard PCI-Express X1 slot	P	+
PCI Extension	Single PCI slot, configurable for 3.3 V or 5 V VIO Note: Only one of the extension slots is functional at a time: PCI or PCI-Express	P	+
I2C	2 interfaces (one SMBus -up to 1MHz and one I2C up to 400kHz), on 100-mil header	+	+
MMC/SD/SDIO	One full-size SD socket	+	+
GPIO	Up to 18 lines, on a 100-mil header	+	+
RTC Battery	Real-time clock operated from on-board rechargeable lithium battery	+	+

Table 4 Electrical, Mechanical, and Environmental Specifications

Feature	Specifications
Supply Voltage	High efficiency switched power supply. Support of sleep mode Input - unregulated 7 V to 20 V
Power Consumption	5W to 9W in full activity, depending on CPU speed and selected features Below 0.4W in sleep mode
Dimensions	190 mm x 170 mm Height ranges from 10 mm to 37 mm, depending on the connectors assembled. The height specified includes the CM-iTC module
Operation Temp. (case)	Commercial: 0°C to 70°C
	Extended: -20°C to 70°C
	Industrial: -40°C to 85°C
Storage Temp.	-40°C to 85°C
Relative Humidity	10% to 90% (operation) 05% to 95% (storage)
Shock	50 G / 20 ms
Vibration	20 G / 0 - 600Hz
MTBF	> 100,000 hours

3 System Components

3.1 PCIe Mux

The SB-iTC has only one routed PCIe interface that can be muxed to the PCIe x1 slot:

- To select the PCIe x1 slot, set jumper E7 to [1-2], or leave it open
- To select the PCIe-> PCI bridge, set jumper E7 to [2-3]

Only one device of the above two options can be used at a time. LED DS10 lights up when the PCIe->PCI bridge path is selected.

3.2 PCIe to PCI Bridge

The SB-iTC implements PCIe to PCI conversion using Pericom's PI7C9X111L Bridge. Such an extension allows the user to take advantage of the large variety of existing PCI peripheral devices, offering a wide range of functions.

There are two additional power supplies for this conversion function implemented on the SB-iTC:

- DC-to-DC power supply unit provides 1.0 V for the main PCI power rail
- DC-to-DC power supply unit provides 1.0 V for the auxiliary PCI power rail

Key features are:

- Compliant with PCI Express Base Specification, Revision 1.1
- Physical Layer interface (x1 link with 2.5Gb/s data rate)
- Lane polarity toggle
- Virtual Isochronous support (upstream TC1-7 generation, downstream TC1-7 mapping)
- Beacon support
- CRC (16-bit), LCRC (32-bit)
- ECRC and advanced error reporting
- Maximum payload size up to 512 bytes
- Compliant with PCI-to-PCI Bridge Architecture Specification, Revision 1.2
- Compliant with PCI Bus PM Interface Specification, Revision 1.1
- Compliant with PCI Hot-Plug Specification, Revision 1.1
- 3.3V PCI signaling with 5V I/O tolerance
- Provides two level arbitration support for four PCI Bus masters
- 16-bit address decode for VGA
- Support for Subsystem Vendor ID and Subsystem Device ID
- PCI INT interrupt or MSI function support
- Power consumption typically less than 0.5 W
- Extended commercial temperature range (0°C to 85°C)

The SB-iTC PCI implementation is 5V tolerant and supports dual 3.3V/5V VIO configured by jumper E8:

- To select 5V, place the E8 jumper position at [1-2]
- To select 3.3V, place the E8 jumper position at [2-3] or left open (default)

The PCI_AD20 signal is used for slot IDSEL.

The PCIe->PCI Bridge uses an internal clock generator for the PCI slot. The internal clock generator can be changed by the P52 and P53 jumpers according to the table below:

Table 5 P52 and P53 jumpers

P52	P53	Clock Frequency
Open	Open	33Mhz
Open	Closed	66Mhz
Closed	Open	25Mhz
Closed	Closed	50Mhz

The PCI slot does not implement JTAG functionality or -12V. These signals can be accessed through TP18.

For PCI cards needing a +12V supply, this can be supplied through P43.

3.3 Audio Codec

The SB-iTC implements on-board 5.1 audio, using the IDT 92HD83Cx chip. See the CM-iTC documentation for more information regarding codec capabilities.

The codec has three configurable HP/line outputs, two configurable MIC/LINE in inputs, one dedicated stereo speaker output (2W) with support for 8/4 ohm speakers, and one SPDIF output provided through RCA and optical connectors.

This HDA device uses channel #1 (SDATAIN_1) output to the chipset for communication, while the on-core audio codec uses channel #0 for this, so jumper E9 (2-3) should be used for enabling communication. Operating systems provide support for switching between two channels (CODEC0 and CODEC1).

Setting E9 to [1-2] routes CODEC1 input to extension slot P42 for applications requiring such an interface.

3.4 LCD Power Switch

SB-iTC provides a power switch for correct power sequencing of the LCD display. The power switch is controlled by the LVDS_EN, which is generated by the CM-iTC onboard graphics controller.

3.5 Analog VGA

The SB iTC implements on-board analog VGA with the FMS3818 video DAC (configuration option 'M', used in conjunction with CM iTC configuration option 'L').

3.6 Video Extension Slot

SB-iTC provides an SDVO interface on connector P42, which makes it possible to add additional video signaling interfaces, such as a DVI monitor output for external DVI video devices.

CompuLab offers the EB-DVI extension board for connecting to the SDVO interface to convert SDVO into DVI.

See <http://www.complab.co.il/iTC/html/iTC-developer.py> for more information and available extensions.

3.7 DC Power Supply

The SB-iTC is powered by unregulated 7.0-20V DC power source.

Figure 2 Power Supply Path

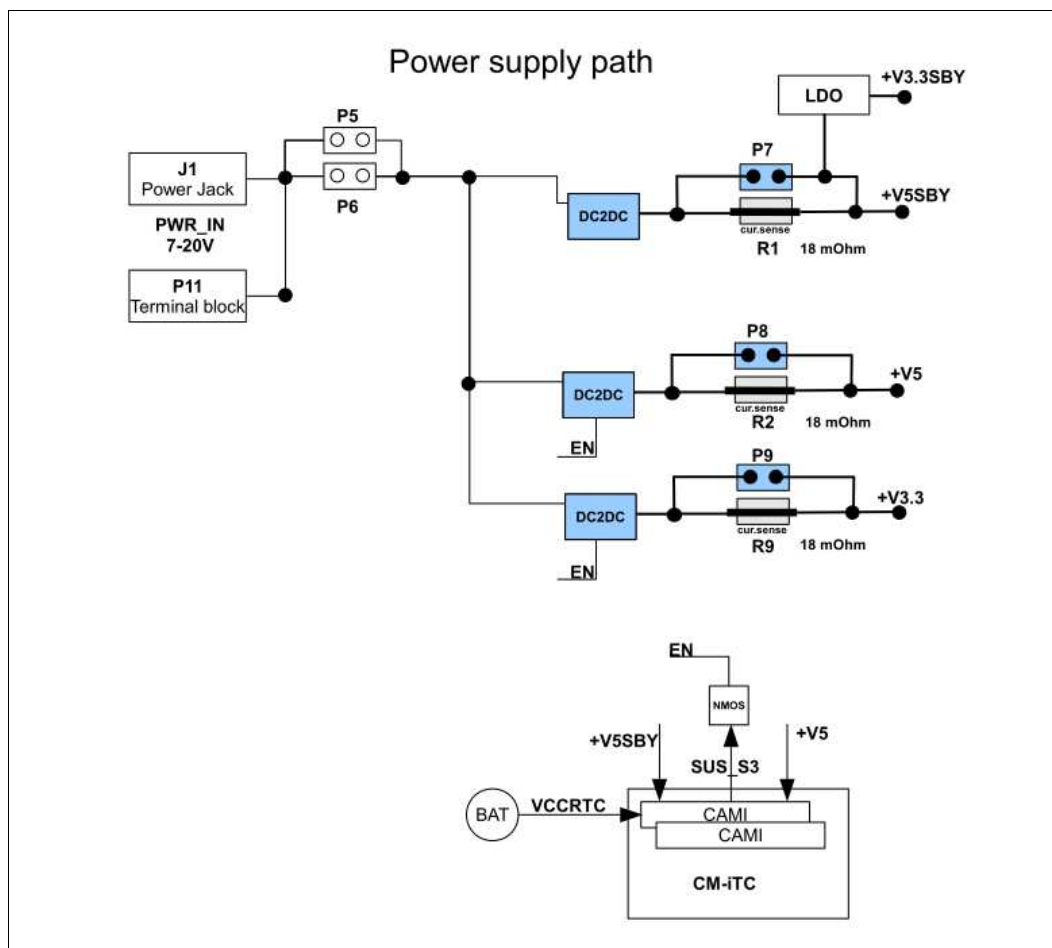

The system power up sequence is described below:

1. +V5SBY is UP (on the base - red LEDs DS14 and DS16) and stable on the CM-iTC inputs.
2. CM-iTC enables all of the internal standby circuits, then the automatic power-on switches its state to ON and indicates readiness by drawing the SUS_S3 signal to LOW (green LEDs DS15 and DS17 on the base).
3. Inverted SUS_S3 signal (EN) enables the +V5 and +V3.3 power rails.

Power down /standby sequence:

1. Inverted SUS_S3 signal (EN) disables the +V5 and +V3.3 power rails.
2. +V5SBY remains ON.

For turning ON (S5, S4, S3->S0), power button SW3 should be pressed. The CM-iTC requires only +V5/+V5SBY power rails.

Jumpers P7, P8, and P9 may be used for current consumption measurements. For normal operation, assemble the jumpers. For measuring current consumption, remove the jumper associated with the measured supply and then measure the voltage drop on a current sense resistor (R1, R2, or R9). The value of each current sense resistor is 18 mohm +-1%.

Connector P54 (+V5) is used for supplying the 5V external 2.5" HDD power supply.

Connector P43 (+12V) is used for supplying the 12V to PCI/PCIe applications requiring a 12V supply. In all other cases, 12V can be left unconnected.

USB power supply is limited to 1.5A total and 0.5A per port. The USB power supply has two options, configurable by jumper E10:

- +V5 (S0 only)
- +V5SBY (always on). This option is used for implementing system wakeup by keyboard or mouse

4 SB-iTC CONNECTOR DESCRIPTION

The SB-iTC carrier uses the attached CM-iTC computer-on-module to implement most of the functions provided by the SBC-iTC single-board computer.

To provide these CM-iTC functions, the SB-iTC routes the signals from the CM-iTC's miniature connectors to the SB-iTC standard connectors.

For the CM-iTC function descriptions, see the CM-iTC Reference Guide.

This chapter describes only the external interface connectors. Chapter 3 provides the specifications of those functions implemented on the SB-iTC itself.

For the CM-iTC function descriptions, see the CM-iTC Reference Guide.

4.1 COM1 Connector (P40B)

The COM1 connector (P40B) is a standard DB9 connector compatible with RS-232 levels.

Table 6 COM1 Connector (P40B)

Pin	Name	Pin	Name
S1	COM1-DCD	S6	COM1-DSR
S2	COM1-RXD	S7	COM1-RTS
S3	COM1-TXD	S8	COM1-CTS
S4	COM1-DTR	S9	COM1-RI
S5	GND		

4.2 COM2, COM3, COM4 Connectors (P41, P1163, P1060)

COM2, COM3 and COM4 ports are routed to the on-board RS232 ultra-mini connectors. All signals are at RS232 levels.

Table 7 P41, P1163, P1060 connectors pin-out

Pin	Signal Name	Pin	Signal Name
1	COM2_TXD	5	NC
2	NC	6	NC
3	COM2_RXD	7	NC
4	NC	8	GND

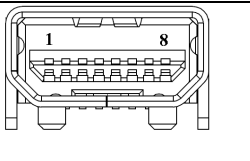

Table 8 P41, P1163, P1060 connector data

Manufacturer	Mfg. P/N	Mating connector
Wieson	G3169-500001	Wieson, P/N: 4306-5000

The connector is compatible with the CABDB9UMP cable supplied by CompuLab.

4.3 RS485 Connector (P1159)

The P1159 is a 100-mil header that provides RS485 interface implemented with a RS485 transceiver connected to the COM2 port.

Table 9 P1159 connector pin-out

Pin	Signal Name	Pin	Signal Name
1	GND	6	GND
2	GND	7	COM2_RS485_RXP
3	COM2_RS485_TXN	8	COM2_RS485_RXN
4	COM2_RS485_TXP	9	GND
5	GND	10	GND

4.4 USB Host Connectors (P3B, P4B, U6)

The USB connector (P3B, P4B, U6) is a standard dual USB Type-A stacked connector. P3B is used for the USB0 and USB1 interfaces. P4B is used for the USB2 and USB3 interfaces. U6 is used for the USB4 and USB5 interfaces.

Table 10 USB Connector (P3B, P4B, U6)

USB Interface 0,2,4		USB Interface 1,3,5	
Pin	Name	Pin	Name
1	VBUS	5	VBUS
2	DN	6	DN
3	DP	7	DP
4	GND	8	GND

4.5 USB Device Connector (P1033)

The USB device port of the CM-iTC is routed to the micro-USB type AB connector (P1033).

Table 11 P1033 connector pinout

Pin	Signal Name
1	USB_DEV_BUS
2	USB_DEV_DN
3	USB_DEV_DP
4	NC
5	GND

4.6 GPIO, Misc Header (P50)

The GPIO connector (P50) is a 2 x 20 line connector on a 100 mil header.

Table 12 GPIO, Misc Header (P50)

Pin	Name	Pin	Name
01	GPIO_SUS7	21	SMB_DATA
02	GND	22	+V3.3
03	GND	23	SMB_CLK
04	GPIO1	24	FAIL_BOOT
05	SB_GPIO0	25	TC_SPKR
06	SB_GPIO3	26	GND
07	SB_GPIO5	27	+V5
08	GND	28	PWRBTN#
09	SB_GPIO6	29	CAN_VCC
10	GPIO4	30	GND
11	SB_GPIO8	31	CAN_L
12	+V5	32	BASE_POWERGD
13	SB_GPIO1	33	CAN_H
14	SB_GPIO9	34	LVDS_BCTL_OUT
15	SB_GPIO2	35	CAN_GND
16	SB_GPIO10	36	LPC_SERIRQ
17	SMB_ALERT#	37	GND
18	SB_GPIO4	38	SB_GPIO11
19	GND	39	RST_IN#
20	SB_GPIO7	40	RESET#

4.7 SATA Connectors (P35, P1058)

The SATA connectors (P35 and P1058) are standard Serial ATA connector.

Table 13 SATA Connector (P35, P1058)

Pin	Name
1	GND
2	SATA-TXP
3	SATA-TXN
4	GND
5	SATA-RXN
6	SATA-RXP
7	GND

4.8 SDIO Connector (P34)

P34-SDIO0

SDIO1 is implemented as an on-board micro-SD interface that does not have write protect (input), so it is implemented with jumper P36.

Table 14 SDIO Connector (P34)

Pin	Name
1	CD/DAT[3]
2	CMD
3	VSS1
4	VDD
5	CLK
6	VSS2
7	DAT[0]
8	DAT[1]
9	DAT[2]

4.9 Audio Interface (P21, P22, P23, P24, P25, P26, P27, P28, P29, P30, P31, P32, U9, E12, E13, E14)

SB-iTC provides CM-iTC and base-board audio interfaces. CM-iTC audio relies on the HDA base using the SDATAIN0 chipset input. Base-board audio uses SDATAIN1 utilizing the provision for an additional external codec (such as an HDMI chip) on the SDVO extension slot - configurable through jumper E9. The schematic below describes the audio sub-system:

Figure 3 Audio Interface Block Diagram

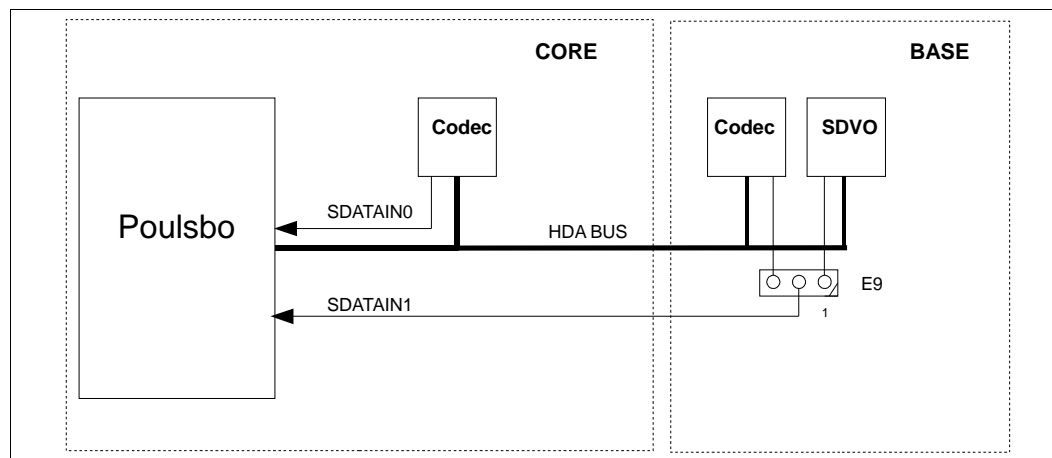

The CM-iTC audio interface provides three analog connectors and one RCA-based SPDIF. The base audio has seven outer connectors with RCA and optical SPDIF.

4.9.1 CM-iTC Audio

The following interfaces are provided:

- Stereo headphone / line-out output (functioning controlled by software)
- Stereo line-in / mic-in (x2)
- RCA based SPDIF

Each audio analog interface is connected to a dedicated 3.5 mm jack.

The following diagrams show the general structure of the Core Audio's Jack Pin-out and Mating Plug.

Figure 4 General Structure of the Core Audio's Jack Pin-out and Mating Plug

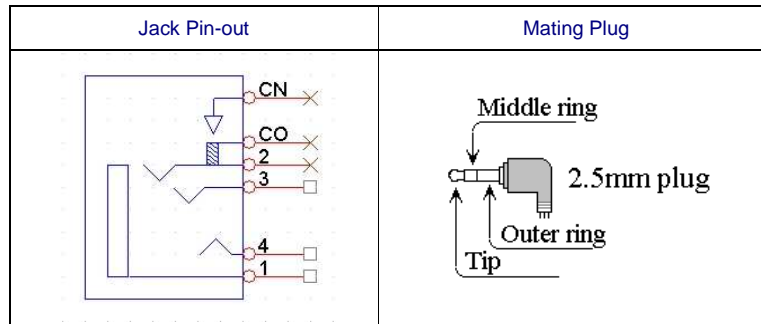

The following three tables provide the mapping details between the Mating Plug and the Pin-out.

Table 15 Headphone/Line-out (P31)

Pin	Name	Mating Plug Pin
1	GND	Outer ring
2	NC	-
3	HP_OUT_R	Middle ring
4	HP_OUT_L	Tip

Table 16 Line-in / Mic-in (P29)

Pin	Name	Mating Plug Pin
1	GND	Outer ring
2	NC	-
3	LINE_IN_R	Middle ring
4	LINE_IN_L	Tip

Table 17 Mic-in / Line-in (P26)

Pin	Name	Mating Plug Pin
1	GND	Outer ring
2	NC	-
3	LINE_MIC_R	Middle ring
4	LINE_MIC_L	Tip

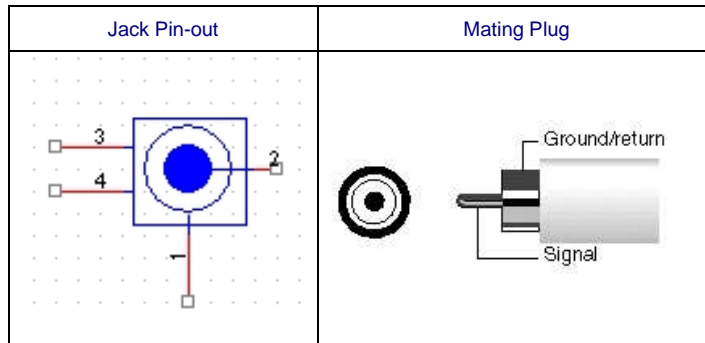
Figure 5 RCA Jack:

Table 18 SPDIF Out (P28) RCA jack:

Pin	Name	Mating plug pin
1	GND	Ground/Return
2	SPDIF_CORE	Signal

4.9.2 Base-board Audio

The following interfaces are provided:

- Stereo headphone/line out (x3)
- Stereo line-in / Mic-in (x2)
- Speaker output x2 (left, right)
- Dual SPDIF (RCA and optical based)

Table 19 Headphone / line out (P22, P23, P25):

Pin	Name	Mating Plug Pin
1	GND	Outer ring
2	NC	-
3	OUT_R	Middle ring
4	OUT_L	Tip

Table 20 Microphone in / Line in (P21, P24):

Pin	Name	Mating Plug Pin
1	GND	Outer ring
2	NC	-
3	IN_R	Middle ring
4	IN_L	Tip

Table 21 SPDIF OUT (P27) RCA jack

SPDIF OUT (U9) comprises an optical transmitter implemented by a 660nm AlGaInP LED and a driver IC. SPDIF OUT transforms the electrical signal to an optical signal for further transmission by a 1 mm diTCeter plastic optical fiber.

Pin	Name	Mating plug pin
1	GND	Ground
2	SPDIF_CORE	Signal

**Table 22 SPEAKER OUT (P30, P32)
W2B, Header, 2x1, 1.25mm (Molex P/N 53261-0271)**

Pin	Name	Mating Plug Pin
1	SPKR+	Ground/Return
2	SPKR-	Signal

4.10 VGA CONNECTOR (P40A)

The VGA connector (P40A) is a standard HDB-15 connector used for direct connection to VGA displays. This connector is available only with the front panel option.

Table 23 CRT VGA CONNECTOR (P40A)

Pin	Name
V1	RED
V2	GREEN
V3	BLUE
V4	N/C
V5	GND
V6	GND
V7	GND
V8	GND
V9	VCC3
V10	GND
V11	N/C
V12	N/C
V13	HSYNC
V14	VSYNC
V15	N/C

4.11 LCD Panel 18-bit Connector (P39)

The LCD Panel connector (P39) is a 40-pin FPC connector for TFT panels that routes an 18-bit parallel RGB interface.

LCD-VDD-EN is an active low ENAVDD signal that should be used in conjunction with the CONLCD-GEN-V2 adapter module, also available from CompuLab

Table 24 LCD Panel Connector (P39)

Pin	Name	Pin	Name
01	NC	21	VCC3
02	LCD-VDD-EN	22	NC
03	GND	23	NC
04	LCD-R0	24	GND
05	LCD-R1	25	NC
06	VCC3	26	LCD-B0
07	LCD-R2	27	VCC3
08	LCD-R3	28	LCD-B1
09	GND	29	LCD-B2
10	LCD-R4	30	GND
11	LCD-R5	31	LCD-B3
12	VCC3	32	LCD-B4
13	LCD-G5	33	GND
14	LCD-G4	34	LCD-B5
15	GND	35	LCD-DE
16	LCD-G3	36	VCC3
17	LCD-G2	37	LCD-LP
18	VCC3	38	LCD-FRM
19	LCD-G1	39	GND
20	LCD-G0	40	LCD-SCK

4.12 LCD Panel 24-bit Connector (P38)

2x20 W2B connector (Hirose DF13A-40DP-1.25V) for TFT panels (not assembled)

Table 25 LCD Panel 24-bit Connector (P38)

Pin	Name	Pin	Name
1	+V5	21	LCD_G4
2	+V5	22	LCD_G5
3	GND	23	LCD_G6
4	GND	24	LCD_G7
5	+V3.3	25	LCD_R0
6	+V3.3	26	LCD_R1
7	LVDS_BEN	27	LCD_R2
8	GND	28	LCD_R3
9	LCD_B0	29	LCD_R4
10	LCD_B1	30	LCD_R5
11	LCD_B2	31	LCD_R6
12	LCD_B3	32	LCD_R7
13	LCD_B4	33	GND
14	LCD_B5	34	GND
15	LCD_B6	35	LCD_SCK
16	LCD_B7	36	LCD_VSYNC
17	LCD_G0	37	LCD_DE

Pin	Name	Pin	Name
18	LCD_G1	38	LCD_HSYNC
19	LCD_G2	39	NC
20	LCD_G3	40	LVDS_EN

4.13 LVDS Panel Connector (P37)

30-pin (2x15) 1.25mm pitch connector

(Hirose DF13A-30DP-1.25V) for LVDS panels

Table 26 LVDS Panel Connector (P37)

Pin	Name	Pin	Name
1	LVDS_BEN	16	LVDS_DP3
2	NC	17	LVDS_DDCDATA
3	LVDS_PWR	18	LVDS_DDCCLK
4	GND	19	NC
5	LVDS_CKN	20	NC
6	LVDS_CKP	21	NC
7	LVDS_PWR	22	NC
8	GND	23	NC
9	LVDS_DN0	24	NC
10	LVDS_DP0	25	NC
11	LVDS_DN1	26	NC
12	LVDS_DP1	27	LVDS_PWR
13	LVDS_DN2	28	GND
14	LVDS_DP2	29	NC
15	LVDS_DN3	30	NC

4.14 PCI Slot (P51)

The PCI slot (P51) is a standard 5V type PCI slot.

The notes in the table below provide description for connections and signals.

Table 27 PCI Slot (P51)

Pin	Name	Notes	Pin	Name	Notes
B1	-12V	Use test point TP18 if needed	A1	TRST#	PU
B2	TCK	Connected to GND	A2	+12V	Ext. +12V
B3	GND		A3	TMS	Connected to GND
B4	TDO	N/C	A4	TDI	Connected to GND
B5	+5V		A5	+5V	
B6	+5V		A6	INTA#	
B7	INTB#		A7	INTC#	
B8	INTD#		A8	+5V	
B9	PRSNT#1	RC delay	A9	RESERVED	N/C
B10	RESERVED	N/C	A10	VIO	3.3V/5V
B11	PRSNT#2	RC delay	A11	RESERVED	N/C
B12	-	N/C	A12	-	N/C

Pin	Name	Notes	Pin	Name	Notes
B13	-	N/C	A13	-	N/C
B14	RESERVED	N/C	A14	3.3Vaux	3.3VSBY
B15	GND		A15	RST#	
B16	CLK		A16	VIO	3.3V/5V
B17	GND		A17	GNT	
B18	REQ#		A18	GND	
B19	VIO	3.3V/5V	A19	PME#	
B20	AD31		A20	AD30	
B21	AD29		A21	+3.3V	
B22	GND		A22	AD28	
B23	AD27		A23	AD26	
B24	AD25		A24	GND	
B25	+3.3V		A25	AD24	
B26	C/BE#3		A26	IDSEL	AD20
B27	AD23		A27	+3.3V	
B28	GND		A28	AD22	
B29	AD21		A29	AD20	
B30	AD19		A30	GND	
B31	+3.3V		A31	AD18	
B32	AD17		A32	AD16	
B33	C/BE#2		A33	+3.3V	
B34	GND		A34	FRAME#	
B35	IRDY#		A35	GND	
B36	+3.3V		A36	TRDY#	
B37	DEVSEL#		A37	GND	
B38	GND		A38	STOP#	
B39	LOCK#		A39	+3.3V	
B40	PERR#		A40	SDONE	PU
B41	+3.3V		A41	SBO#	PU
B42	SERR#		A42	GND	
B43	+3.3V		A43	PAR	
B44	C/BE#1		A44	AD15	
B45	AD14		A45	+3.3V	
B46	GND		A46	AD13	
B47	AD12		A47	AD11	
B48	AD10		A48	GND	
B49	M66EN	Jumper P53	A49	AD9	
B50	5V key		A50	GND	
B51	5V key		A51	GND	
B52	AD8		A52	C/BE#0	
B53	AD7		A53	+3.3V	
B54	+3.3V		A54	AD6	
B55	AD5		A55	AD4	
B56	AD3		A56	GND	
B57	GND		A57	AD2	
B58	AD1		A58	AD0	
B59	VIO	3.3V/5V	A59	VIO	3.3V/5V
B60	ACK64#	PU	A60	REQ64#	PU
B61	+5V		A61	+5V	
B62	+5V		A62	+5V	

4.15 PCIe Slot (P44)

The PCIe slot (P44) is a PCIe x1 extension slot.

Table 28 PCIe Slot (P44)

Pin	Name	Notes	Pin	Name	Notes
B1	+12V	Ext. +12V	A1	PRSNT1#	Con. to GND
B2	+12V	Ext. +12V	A2	+12V	Ext. +12V
B3	+12V	Ext. +12V	A3	+12V	Ext. +12V
B4	GND		A4	GND	
B5	SMCLK	N/C	A5	TCK	NC
B6	SMDAT	N/C	A6	TDI	NC
B7	GND		A7	TDO	NC
B8	+3.3V		A8	TMS	NC
B9	TRST#	NC	A9	+3.3V	
B10	3.3VAux	+V3.3SBY	A10	+3.3V	
B11	WAKE#		A11	RERST#	
B12	RESERVED	N/C	A12	GND	
B13	GND		A13	REFCLK+	
B14	PETp0		A14	REFCLK-	
B15	PETn0		A15	GND	
B16	GND		A16	PERp0	
B17	PRSNT2#		A17	PERn0	
B18	GND		A18	GND	

4.16 SDVO Extension Slot (P42)

The SDVO extension slot (P42) is a video/audio extension input/output connector, providing support for a wide range of extensions, such as DVI, HDMI, and VGA.

Table 29 SDVO Extension Slot (P42)

Pin	Name	Pin	Name
1	GND	2	GND
3	SDVO_RED	4	GND
5	SDVO_RED#	6	SDVO_TVCLKIN
7	GND	8	SDVO_TVCLKIN#
9	GND	10	GND
11	SDVO_GREEN	12	GND
13	SDVO_GREEN#	14	SDVO_INT
15	GND	16	SDVO_INT#
17	GND	18	GND
19	SDVO_BLUE	20	GND
21	SDVO_BLUE#	22	SDVO_STALL
23	GND	24	SDVO_STALL#
25	GND	26	GND
27	SDVO_CLK	28	GND
29	SDVO_CLK#	30	RESET#
31	GND	32	GND
33	GND	34	GND
35	SDVO_CTRLCLK*	36	NC
37	GND	38	NC
39	SDVO_CTRLDATA*	40	NC
41	GND	42	NC
43	HDA_BITCLK	44	NC

Pin	Name	Pin	Name
45	GND	46	NC
47	HDA_RST#	48	+V5
49	HDA_SDATAIN	50	+V5
51	GND	52	+V5
53	HDA_SDATAOUT	54	+V5
55	HDA_SYNC	56	+V5
57	GND	58	+V5
59	NC	60	NC
61	+V5SBY	62	NC
63	+V5SBY	64	+V3.3SBY
65	NC	66	+V3.3SBY
67	NC	68	NC
69	NC	70	NC
71	+V3.3	72	+V3.3
73	+V3.3	74	+V3.3
75	+V3.3	76	+V3.3
77	+V3.3	78	+V3.3
79	+V3.3	80	+V3.3

*SDVO_CTRLCLK and SDVO_CTRLCLK should be pulled up to 2.5 V (when used) on the extension board. See the EB-DVI schematic for an example (<http://www.compulab.co.il/iTC/html/iTC-developer.py>).

4.17 Gigabit Ethernet (P4A & P3A)

The Gigabit Ethernet interfaces (P4A & P3A) are provided through standard RJ45 connectors P4A and P3A.

Table 30 Ethernet Port 1 & 2 (P4A & P3A)

Pin	Name	Description
1	BI_DA+	Bi-directional pair A +
2	BI_DA-	Bi-directional pair A -
3	BI_DB+	Bi-directional pair B +
4	BI_DC+	Bi-directional pair C +
5	BI_DC-	Bi-directional pair C -
6	BI_DB-	Bi-directional pair B -
7	BI_DD+	Bi-directional pair D +
8	BI_DD-	Bi-directional pair D -

4.18 Power Connector (J1, P11, P43, P54)

Table 31 J1: DC Jack, External - 3.9mm, Inner pin - 1.3mm DiTCeter

Pin	Name	Description
1	PWR_IN	Inner pin
2	GND	Outer ring

Table 32 P11: 2-node Terminal Block used as an External Charger Power Supply/Main Power (in Parallel with J1)

Pin	Name
1	PWR_IN
2	GND

Table 33 P43: 2-node Terminal Block used as an External +12V Source Input for PCI/PCIe Slots

Pin	Name
1	+V12_EXT
2	GND

Table 34 P54: 2-node Terminal Block used as External +5V Source Output for Hard-disk Power (1.5 A Maximum)

Pin	Name
1	+V5
2	GND

5 Mechanical Drawings

5.1 Connector Locations

Figure 6 SB-iTC – Top View

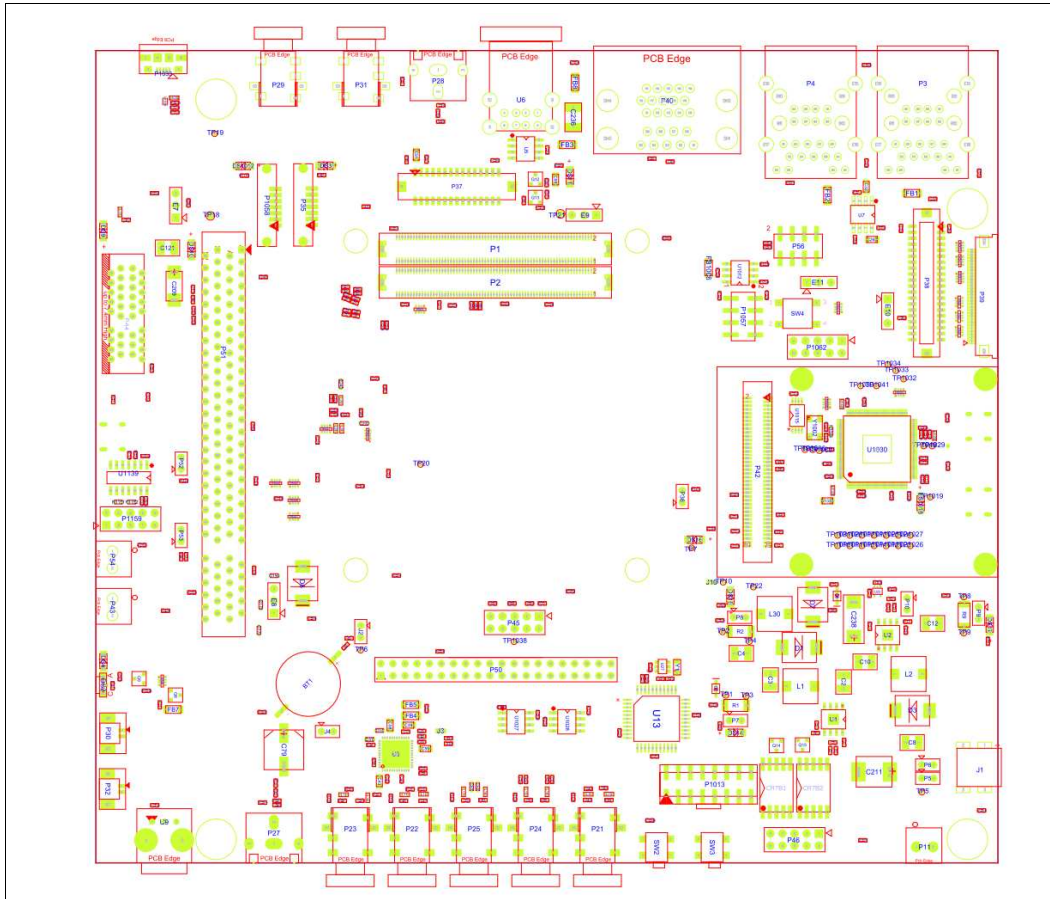
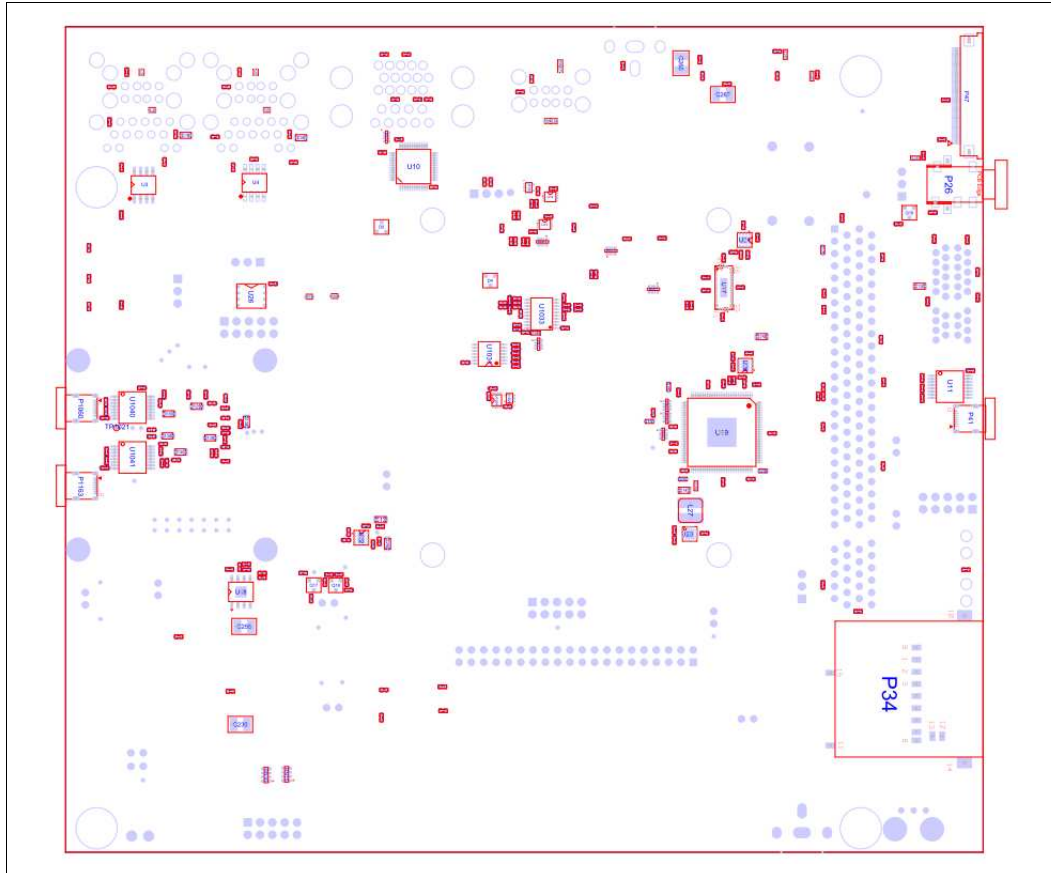

Figure 7 SB-iTC – Bottom View

5.2 Default Jumper Settings

Jumper	Position	Notes
P6	Closed	
P7	Closed	Bypass R1
P8	Closed	Bypass R2
P9	Closed	Bypass R9
P10	Open	
P52	Open	Default: PCI clock 33MHz
P53	Open	
E7	Open	Default: PCIe->PCIe slot
E8	1-2	PCI VIO to +5 V
E9	Open	Default: on-base codec disconnected
E10	2-3	USB power from +V5SBY
E11	2-3	
J2, J4	Open	

5.3 SB-iTC jumpers and connectors

P1, P2	CM-iTC mating baseboard connectors
P3, P4	Dual USB + Ethernet Combo connector
P5, P6	Input power jumpers
P7	Jumper for 5VSBY
P8	Jumper for 5V
P9	Jumper for 3.3V
P10, P45, P46, P47, P56	DEBUG, don't use
P11	Alternative main power supply/output
P21, P22, P23, P24, P25, P26, P29, P31	Core & Base 3.5mm Audio jacks
P27, P28	Core & Base SPDIF RCA jacks
P30, P32	Base audio speaker W2B 1x2 connectors
P34	SDIO connector
P35, P1058	SATA connectors
P36	SDIO1 (on board) Write protect jumper
P37	2x15 LVDS connector
P38	2x20 W2B 24-bit LCD connector
P39	40-pin FPC 18-bit LCD connector
P40	Combo DB9/DB15 VGA and COM connector
P41	COM2 connector
P42	SDVO extension 2x80 connector
P43	PCI/PCIE external 12V source
P44	PCIEx1 connector
P50	2x20 header (GPIO's and other)
P51	Standard PCI connector
P52, P53	PCI clock input switch
P54	+5V output power for external HDD
P1013	External functionality connector
P1060	COM4 connector
P1163	COM3 connector
E7	PCIE –PCIE bridge selection jumper
E8	3.3/5V PCI VIO power selection jumper
E9	Second codec input (to chipset) selector
E10	USB power source selector (5V/5VSBY)
E11	Core BIOS/ Base BIOS selector
J1	Power jack
J2	RTC reset jumper
J4	Ext. RTC battery input
U6	Dual USB connector
U9	Optical SPDIF output
DS2, DS4	SDIO0 power/activity LED's
DS3	SATA activity LED
DS6	SDIO1 (on module) activity LED
DS7, DS8	Debug LED's
DS9/DS10	PCIE/PCI bridge select LED's
DS11	LVDS power enable LED
DS14, DS15, DS16, DS17, DS18	Power indicator LED's
SW1	Debug
SW2	Hardware reset switch
SW3	Power button (on / off / suspend)
SW4	Core BIOS / Base BIOS button selector

6 Operational Characteristics

6.1 Power Output Specifications

Below are specification ratings for the main power rails in the system.

Core configuration: CM-iTC-D1G-C1300-N8-E2-A-H

Base configuration: SB-iTC-M-P-A

Table 35 Power Output Specifications

Power Rail	Maximum Allowed Output Current	Average Consumption*	Notes
5 V	2.5 A	0.7 A	
5 VSBY	2.5 A	0.31 A	
3.3 V	2.5 A	0.53 A	Not used by the CM-iTC
3.3 VSBY	0.4 A	Derived from 5 VSBY	

*Average consumption is measured as follows:

- Without an external HDD
- USB power is supplied by +V5SBY
- Using a USB and mouse keyboard with an EB-DVI video extension card
- With PCIe routed directly to the PCIEX1 slot (PCIe->PCI bridge disabled)

6.2 Operating Temperature Ranges

SB-iTC is available with three options of operating temperature range, as in the following table.

Table 36 Operating Temperature Ranges

Range	Temp.	Description
Commercial	0° to 70° C	Sample boards from each batch are tested for the lower and upper temperature limits. Individual cards are not tested.
Extended	-20° to 70° C	Every board undergoes a short test for the lower limit (-20° C) qualification.
Industrial	-40° to 85° C	Every board is extensively tested for both lower and upper limits and at several midpoints.