

SBC-IOT-IMX7

Reference Guide



© 2019 CompuLab

No warranty of accuracy is given concerning the contents of the information contained in this publication. To the extent permitted by law, no liability (including liability to any person by reason of negligence) will be accepted by CompuLab, its subsidiaries or employees for any direct or indirect loss or damage caused by omissions from or inaccuracies in this document.

CompuLab reserves the right to change details in this publication without notice.

Product and company names herein may be the trademarks of their respective owners.

CompuLab
17 Ha Yetzira str, Yokneam Illit
26290, Israel

Tel: +972 (4) 8290100
<http://www.compulab.com>
Fax: +972 (4) 8325251

Table of Contents

1	INTRODUCTION	6
1.1	About This Document	6
1.2	Related Documents	6
2	OVERVIEW.....	7
2.1	Highlights.....	7
2.2	Specifications	8
2.3	Block Diagram	9
3	CORE SYSTEM COMPONENTS.....	10
3.1	i.MX 7Dual SoC	10
3.2	System Memory	11
3.2.1	DRAM.....	11
3.3	DVI Output	11
3.4	Audio Subsystem	11
3.5	USB.....	11
3.5.1	Native USB2.0 ports	11
3.5.2	Onboard USB2.0 Hub	11
3.6	Wireless interfaces	12
3.6.1	WLAN Only.....	12
3.6.2	Dual Band WLAN & Bluetooth	12
3.6.3	Cellular.....	13
3.7	Ethernet	14
3.7.1	1000BASE-TX ports.....	14
3.7.2	POE IEEE 802.3af PD	14
3.8	PCI-Express	14
3.9	MMC / SD.....	14
3.10	RS-485.....	14
3.11	RS-232.....	15
3.12	Serial Debug Console	15
3.13	Embedded I/O connector.....	15
4	SYSTEM LOGIC.....	16
4.1	Power Subsystem	16
4.1.1	Power Rails	16
4.1.2	Power Modes	16
4.1.3	RTC Back-Up Battery.....	16
4.2	Firmware Boot Options.....	16
4.3	Real Time Clock	17
5	INTERFACES AND CONNECTORS.....	18

5.1	DVI Connector (J3).....	18
5.2	DC Power Jack (J4).....	18
5.3	Micro-SD Socket (P18).....	19
5.4	uSIM socket (P6)	19
5.5	Audio Jacks (P16, P17).....	19
5.6	USB Host Connectors (P10, P11, P12 and P13).....	19
5.7	USB Console connector (P3)	19
5.8	Gigabit Ethernet Connector (P15).....	19
5.9	POE Gigabit Ethernet Connector (P14)	20
5.10	RS-485 / CAN connector (P9).....	20
5.11	RS-232 connector (P8)	20
5.12	mPCIe Socket (P12)	21
5.13	Power Button (SW1)	21
5.14	Embedded I/O connector	22
5.15	Indicator LED (DS1)	22
6	MECHANICAL DRAWINGS.....	23
7	OPERATIONAL CHARACTERISTICS.....	24
7.1	Absolute Maximum Ratings	24
7.2	Recommended Operating Conditions	24

Table 1 Document Revision Notes

Date	Description
March 2018	<ul style="list-style-type: none">• First release
June 2019	<ul style="list-style-type: none">• Fixed embedded I/O header pin-out in section 5.14

1 INTRODUCTION

1.1 About This Document

This document is part of a set of documents providing information necessary to operate and program Compulab SBC-IOT-IMX7.

1.2 Related Documents

For additional information not covered in this manual, please refer to the documents listed in Table 2.

Table 2 Related Documents

Document	Location
SBC-IOT-IMX7 Resources	http://www.compulab.com/products/sbcs/sbc-iot-imx7-nxp-i-mx-7-internet-of-things-single-board-computer/#devres

2 OVERVIEW

2.1 Highlights

- NXP i.MX 7Dual CPU, dual-core Cortex-A7 1GHz
- Up to 2GB DDR3 and 32GB eMMC
- 3G/LTE modem, WiFi 802.11a/b/g/n, BT 4.1
- 2x 1000Mbps Ethernet, 4x USB2, RS485, RS232
- Support for a PoE powered mode
- Miniature size – 100 x 80 x 20 mm
- Designed for reliability and 24/7 operation
- Wide temperature range of -40C to 85C

2.2 Specifications

Table 3 System

Feature	Specifications
CPU	NXP (Freescale) i.MX 7Dual ARM Cortex-A7, 1GHz
Memory	512MB – 2GB, DDR3L-1066
Storage	eMMC flash, 4GB - 32GB
	Micro-SD socket

Table 4 Display and Graphics

Feature	Specifications
Display	DVI on HDMI plug up to 1920 x 1080 @ 60Hz

Table 5 Network

Feature	Specifications
Ethernet	Up to 2x1000 Base-TX Ethernet port, RJ45 connectors (optional)
	POE PD, class IEEE 802.3af (optional)
WiFi	802.11b/g/n WiFi interface (optional) TI WiLink 8 WL1801 module
	Dual-band 2x2 802.11a/b/g/n WiFi interface (optional) TI WiLink 8 WL1837 module
Bluetooth	Bluetooth 4.1 BLE TI WiLink 8 WL1837 module
Cellular	4G/3G cellular communication module (via mini-PCie socket, optional) On-board micro-SIM card socket

Table 6 I/O

Feature	Specifications
Audio	Audio codec with analog stereo output and stereo input, 3.5mm audio jacks
USB	Four USB 2.0 high-speed ports, standard A-type connectors, max current 1A per port, 2A in total
Serial	1x serial console via UART-to-USB bridge, micro-USB connector
	1x RS232 port, ultra-mini serial connector
	1x RS485 port, half-duplex 2-wire, RJ11 connector
CAN	1x CAN bus interface, RJ11 connector * only available with “Y” configuration option, precludes RS485 port
PCIe	mini-PCIe socket, full-size
Expansion header	1xI2C, 1xUART RX/TX, 4x GPIOs, 1xSPI with a single chip select, 1x2 I2C shared with SPI.

Table 7 Mechanical and Environmental

Supply Voltage	Unregulated 8V to 24V
Dimensions	100 x 80 x 20 mm
Weight	80 grams
MTTF	> 200,000 hours
Operation temperature	Commercial: 0° to 70° C Extended: -20° to 70° C Industrial: -40° to 85° C

2.3 Block Diagram

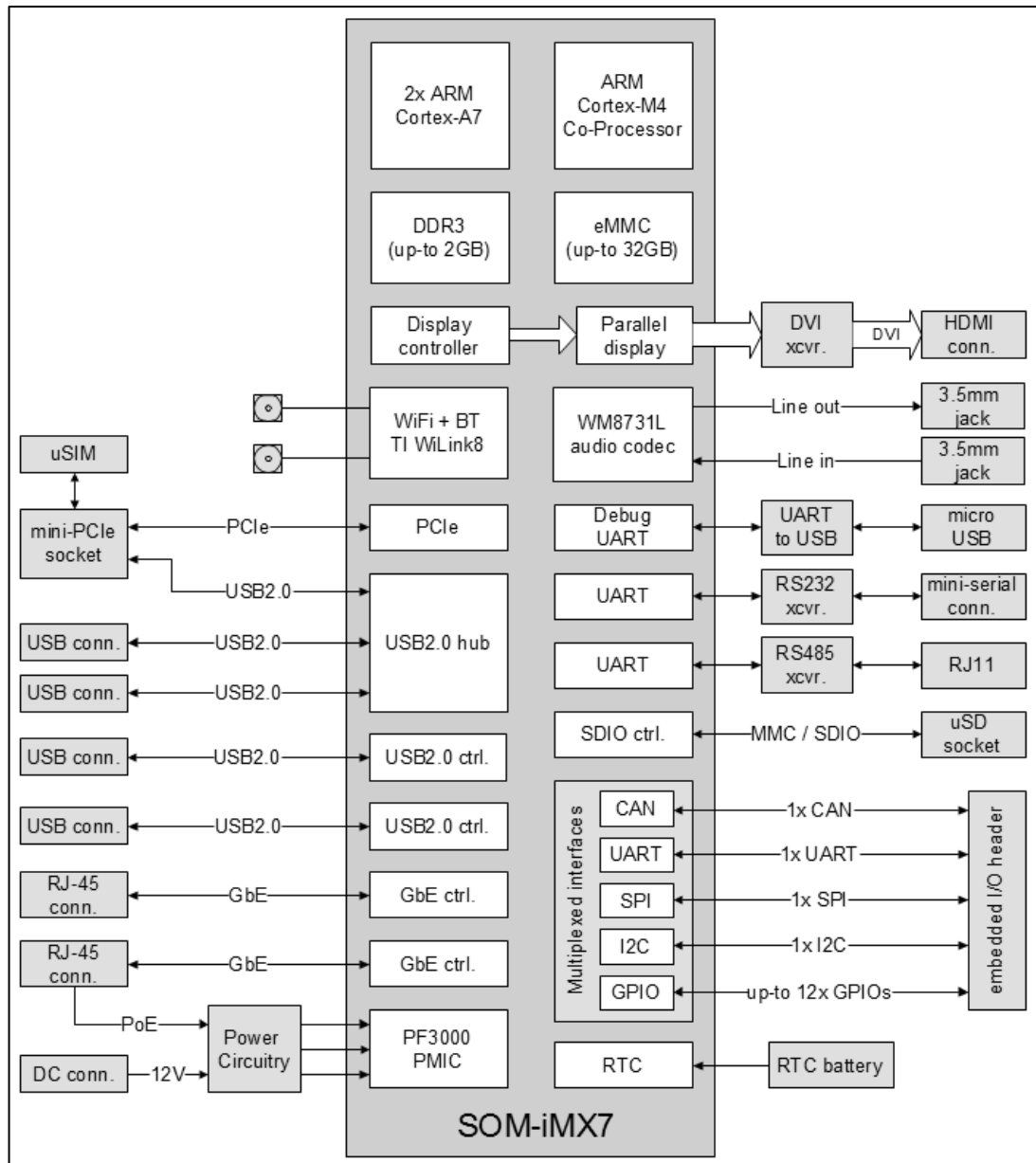

3 CORE SYSTEM COMPONENTS

3.1 i.MX 7Dual SoC

The i.MX 7Dual family of processors combines an implementation of two ARM® Cortex®-A7 cores intended for high-level O/S, with an ARM® Cortex®-M4 core dedicated for real-time tasks. The i.MX 7Dual has the following main features:

- Two ARM Cortex-A7 Cores (with TrustZone® technology), each core includes:
 - Up to 1GHz operation frequency
 - 32 KByte L1 Instruction Cache, 32 KByte L1 Data Cache
 - Private Timer and Watchdog
 - NEON MPE coprocessor
- One ARM Cortex-M4 Core dedicated for real-time tasks, with the following features:
 - 200MHz operation frequency
 - MPU, FPU
 - 16 KByte instruction cache, 16 KByte data cache
 - 64 KByte TCM (tightly-coupled memory)
- Cryptographic acceleration and assurance module, containing cryptographic and hash engines supporting DPA (differential power analysis) protection, 32 KB secure RAM, and true and pseudo-random number generator (NIST certified)
- PXP—PiXeL processing pipeline for imaging resize, rotation, overlay, and CSC. Offloading key pixel processing operations are required to support the display applications

Figure 1 i.MX 7Dual Block Diagram

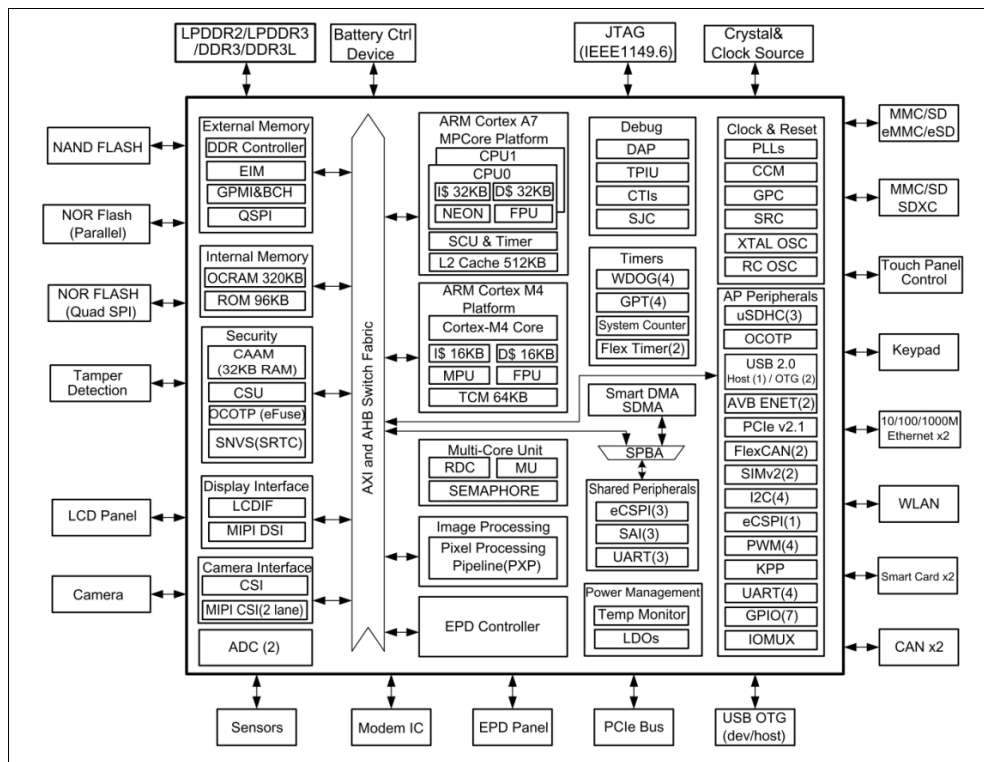

3.2 System Memory

3.2.1 DRAM

SBC-IOT-IMX7 is available with up to 2GB of onboard DDR3L memory. The DDR3L data bus is 32-bits wide and operates at 533 MHz clock frequency (DDR3-1066).

3.2.2 Bootloader Storage

SBC-IOT-IMX7 is assembled with 2MBytes of SPI NOR flash. SPI NOR flash is used for bootloader and configuration blocks storage.

3.2.3 General Purpose Storage

SBC-IOT-IMX7 is available with up to 32GB eMMC onboard storage. The eMMC storage device is designed to store the operating system (kernel & root filesystem) and general purpose (user) data.

3.3 DVI Output

SBC-IOT-IMX7 features a DVI transmitter that is based on the TFP410. The DVI interface is designed to be used for initial configuration or troubleshooting, in addition/alternative to the RS232 / USB interfaces. SBC-IOT-IMX7 device's DVI output signals are routed to the display output HDMI connector. The DVI transmitter is connected to the i.MX 7Dual 24-bit parallel RGB interface and supports up to 1920 x 1080 resolution.

The DVI DDC is implemented with the i.MX 7Dual I2C-3 interface.

3.4 Audio Subsystem

SBC-IOT-IMX7 analog audio functionality is implemented by interfacing the Wolfson WM8731L audio codec with the i.MX 7Dual SAI1 port. The audio out and audio in signals are routed to connectors P16 and P17 respectfully. The WM8731L codec supports the following main features:

3.5 USB

3.5.1 Native USB2.0 ports

SBC-IOT-IMX7 features two USB2.0 ports that are derived directly from i.MX 7Dual USB subsystem. The ports are routed to P10 and P13. The USB ports support the following main features:

- High speed, full speed and low-speed operation in host mode.
- High speed and full speed operation in peripheral mode.
- Up to 8 bi-directional endpoints.

3.5.2 Onboard USB2.0 Hub

SBC-IOT-IMX7 is equipped with an onboard USB2.0 hub supporting three downstream USB2.0 host ports. The three additional ports are implemented through a combination of the i.MX 7Dual on-chip HSIC high-speed host-only port with the Microchip USB3503 USB hub. The USB hub supports the following main features:

- Three USB 2.0 High Speed (480Mbps) compatible downstream ports
- Supports either Single-TT or Multi-TT configurations for Full-Speed (12Mbps) and Low-Speed (1.5Mbps) connections

3.6 Wireless interfaces

SBC-IOT-IMX7 optional wireless communication capabilities are implemented with one of the following two assembly options:

- 2.4GHz WiFi-only capability, Implemented with the “W” ordering option of SBC-IOT-IMX7. Please refer to [WLAN Only](#) section for additional details.
- Dual-Band WiFi and Bluetooth capabilities, Implemented with the “WAB” ordering option of SBC-IOT-IMX7. Please refer to [Dual Band WLAN & Bluetooth](#) section for additional details.

3.6.1 WLAN Only

SBC-IOT-IMX7 WLAN Only capabilities are based on the optional Texas Instruments WL1801MOD WLAN module soldered onboard.

WL1801MOD is a WiLink™ 8 based Single-Band combo module enabling Wi-Fi® functionality with SBC-IOT-iMX7. WL1801MOD supports the following features:

- Support of IEEE Std 802.11a, 802.11b, 802.11g and 802.11n.
- 20- and 40-MHz SISO and 20-MHz 2 x 2 MIMO at 2.4 GHz for High Throughput: 80 Mbps (TCP), 100 Mbps (UDP).
- 2.4-GHz MRC Support for Extended Range.
- Wi-Fi Direct Concurrent Operation (Multichannel, Multirole).

3.6.2 Dual Band WLAN & Bluetooth

SBC-IOT-IMX7 can be optionally assembled with the Texas Instruments WL1837MOD WLAN/Bluetooth module soldered onboard.

WL1837MOD is a WiLink™ 8 based Dual-Band industrial module enabling Wi-Fi®, Bluetooth®, and Bluetooth Low Energy (BLE) functionality. WL1837MOD supports the following features:

- Support of IEEE Std 802.11a, 802.11b, 802.11g and 802.11n.
- 20- and 40-MHz SISO and 20-MHz 2 x 2 MIMO at 2.4 GHz for High Throughput: 80 Mbps (TCP), 100 Mbps (UDP).
- 2.4-GHz MRC Support for Extended Range and 5-GHz Diversity Capable.
- Wi-Fi Direct Concurrent Operation (Multichannel, Multirole).
- Bluetooth 4.1 Compliance and CSA2 Support.
- Dedicated Audio Processor Support of SBC Encoding + A2DP.
- Dual-Mode Bluetooth and BLE.

3.6.3 Cellular

SBC-IOT-IMX7 cellular interface is implemented with a mini-PCIe modem module and a micro-SIM socket. In order to setup SBC-IOT-IMX7 for cellular functionality install an active SIM card into micro-SIM socket P6. The cellular module should be installed into mini-PCIe socket P4.

3.6.3.1 Cellular module and SIM card installation

Figure 2 Service area – mini-PCIe and SIM sockets

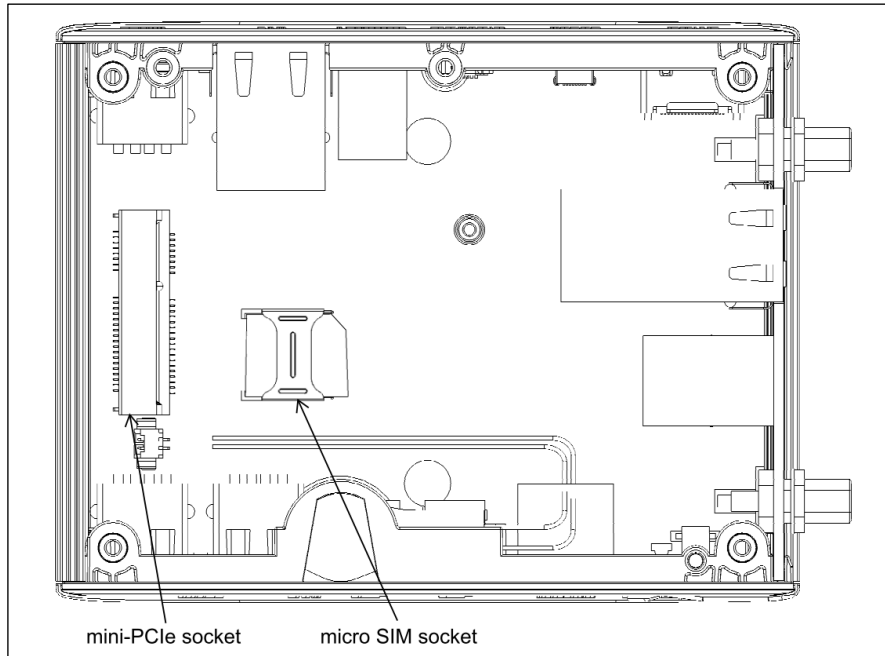
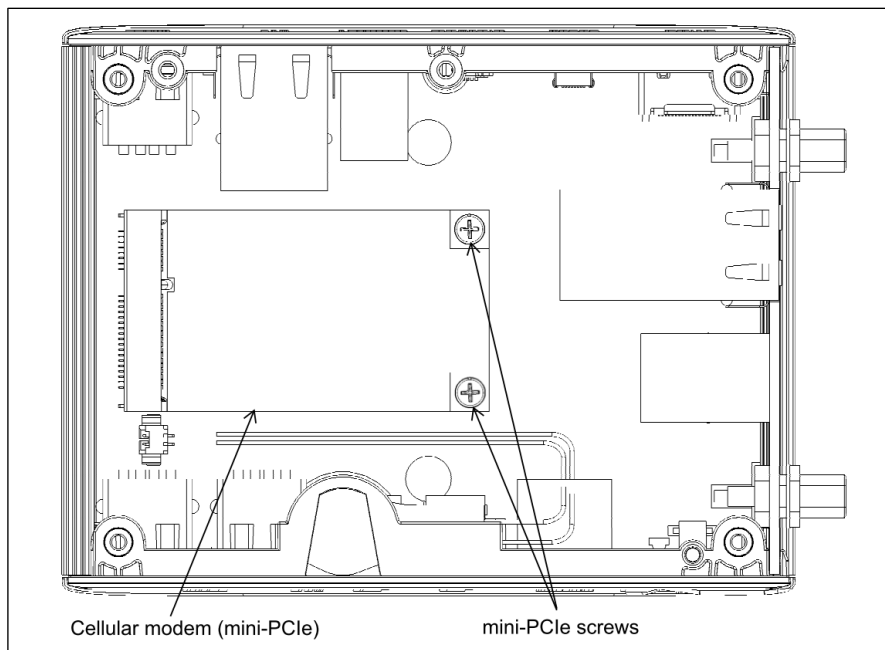

Figure 3 Service area – mini-PCIe module



3.7 Ethernet

3.7.1 1000BASE-TX ports

SBC-IOT-IMX7 incorporates up to two full-featured 1000BASE-TX ports implemented with the two MACs built into the i.MX 7Dual SoC, coupled with two AR8033 RGMII Ethernet PHYs from Atheros. The Ethernet ports are available on RJ45 connectors P14 and P15. Both Ethernet interfaces support the following main features:

- 10/100/1000 BASE-T IEEE 802.3 compliant.
- IEEE 802.3u compliant Auto-Negotiation.
- Supports all IEEE 1588 frames - inside the MAC.
- Automatic channel swap (ACS).
- Automatic MDI/MDIX crossover.
- Automatic polarity correction.
- Activity and speed indicator LED controls.

3.7.2 POE IEEE 802.3af PD

SBC-IOT-IMX7 features optional support for POE networks, eliminating the need for external power supply if connected to POE PSE enabled network. SBC-IOT-IMX7 POE PD is an IEEE 802.3af class device that can accept up to 13.5W from the network to the system needs. POE PD implemented with ON semiconductors NCP1090 interfaced to RJ45 connector P14.

3.8 PCI-Express

SBC-IOT-IMX7 is equipped with a single lane PCI Express port (PCIe) v2.1 port. The port is routed to mini-PCIe socket P23. The PCI Express port supports the following main features:

- Single lane compliant with PCI Express base specification v2.1 (6.0Gbps).
- Dual mode operation to function as root complex or endpoint.
- Supports spread spectrum clocking in transmitter and receiver.

3.9 MMC / SD

A single MMC/SD port is available on SBC-IOT-IMX7. The MMC port is derived from the i.MX 7Dual on-chip uSDHC port 1 and routed to micro SD connector P18.

3.10 RS-485

SBC-IOT-IMX7 features a single RS485 port implemented with MAX3491E transceiver connected to i.MX 7Dual UART 7 port. RS485 signals are routed to RJ11 connector P9.

3.11 RS-232

SBC-IOT-IMX7 features a single RS232 port implemented with the MAX3243 transceiver connected to i.MX 7Dual UART port 5. RS232 signals are routed to ultra mini serial connector P8.

The RS232 port supports the following features:

- 16550 compatibility
- 16-byte FIFO for receiver and 16-byte FIFO for transmitter
- Programmable baud rate of up to 250 Kbps
- Configurable data format
- RS-232 bus-pin ESD protection exceeds ± 15 kV using the Human-Body Model

3.12 Serial Debug Console

SBC-IOT-IMX7 features a serial debug console via UART-to-USB bridge over micro USB connector P3. CP2104 UART-to-USB bridge is interfaced with i.MX 7Dual UART port 1. CP2104 USB signals are routed to micro USB connector P3.

3.13 Embedded I/O connector

SBC-IOT-IMX7 features a single embedded connector P7. The embedded connector provides the developer with a reach set of IOs, such as I2C, SPI, UART and more. All the interfaces are derived directly from CL-SOM-iMX7. For additional information, please refer to the CL-SOM-iMX7 Reference Manual.

4 SYSTEM LOGIC

4.1 Power Subsystem

4.1.1 Power Rails

SBC-IOT-IMX7 is powered with a single 12V power supply.

Table 8 Power rails

Signal Name	Type	Description
12V	P	Main power supply. Typical voltage – 12V. Up to 18W
5V	P	Peripherals and USB power supply
V3_VBAT	P	RTC back-up battery power input. Connected to a 3V coin-cell lithium battery.
POE PD	P	POE PSE input. IEEE 802.3af compatible. 36-58 VDC. 375mA max.
GND	P	Common ground.

4.1.2 Power Modes

SBC-IOT-IMX7 supports two hardware power modes.

Table 9 Power modes

Power Mode	Description
ON	All internal power rails are enabled. Mode entered automatically when main power supply is connected.
OFF	i.MX 7Dual core power rails are off, most of the peripherals power rails are off.

4.1.3 RTC Back-Up Battery

SBC-IOT-IMX7 features a 38mAh coin cell lithium battery, which maintains the SBC-IOT-IMX7 RTC whenever the main power supply is not present.

4.2 Firmware Boot Options

SBC-IOT-IMX7 boot sequence defines which interface/media is used by SBC-IOT-IMX7 to load and execute the initial software (such as U-boot). SBC-IOT-IMX7 can load initial software from the following interfaces/media:

- The onboard primary boot device (SPI Flash with pre-flashed boot-loader).
- An external SD/MMC card using the micro SD interface

SBC-IOT-IMX7 will query boot devices/interfaces for initial software in the order defined by the active boot sequence. A total of two different boot sequences are supported by SBC-IOT-IMX7:

- Standard sequence: Designed for normal system operation with the onboard primary boot device as the boot media.
- Alternate sequence: Designed allow recovery from an external boot device in case of data corruption on the onboard primary boot device. Using the alternate sequence allows SBC-IOT-IMX7 to boot from an external SD card, effectively bypassing the onboard SPI Flash.

NOTE: If during an alternate boot sequence, the SBC-IOT-IMX7 cannot load the initial software from the external SD card, SBC-IOT-IMX7 will fall back and try to load the initial software from the onboard SPI flash.

The initial logic value of ALT_BOOT signal over E2 jumper defines which of the supported boot sequences is used by the system.

Table 10 SBC-IOT-IMX7 Boot sequences

Sequence	E2 jumper	First	Second	Third
Standard	Open	Onboard SPI Flash		Micro SD card (1-bit mode)
Alternate	Closed	Micro SD card (4-bit mode)	Onboard SPI Flash	

4.3 Real Time Clock

The SBC-IOT-IMX7 RTC is implemented with the EM Microelectronic EM3027 IC that provides clock and calendar information in BCD format. EM3027 is connected to the I2C-2 port of the i.MX 7Dual SoC. The on-board backup battery keeps the RTC running to maintain clock and time information whenever the main SBC-IOT-IMX7 power supply is not present.

5 INTERFACES AND CONNECTORS

5.1 DVI Connector (J3)

The DVI display output is provided through the standard HDMI connector (J3).

For additional details, please refer to section 3.3 of this document.

5.2 DC Power Jack (J4)

DC power input connector.

Table 11 J4 connector pin-out

Pin	Signal Name	
1	DC IN	
2	GND	

Table 12 J4 connector data

Manufacturer	Mfg. P/N
Contact Technology	DC-081HS(-2.5)

The connector is compatible with the SBC-IOT-IMX7 power supply unit available from CompuLab.

The connector is compatible with the DC Y-cable (CompuLab P/N ACCENC-CABDCIPC) available from CompuLab.

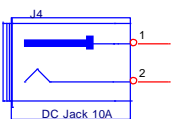
5.3 Micro-SD Socket (P18)

The micro-SD socket (P18) is connected directly to the i.MX 7Dual SDC-1 port. For additional details, please refer to section 3.9 of this document.

Table 13 P18 connector pin-out

Pin	Signal Name	Pin	Signal Name
1	SDIO_DAT2	5	SDIO_CLK
2	SDIO_DAT3	6	GND
3	SDIO_CMD	7	SDIO_DAT0
4	VDD_3V3	8	SDIO_DAT1
9	CD#		

5.4 uSIM socket (P6)

The uSIM socket (P6) is connected to mPCIe socket's (P4) pins 8, 10, 12, 14 and 16.

5.5 Audio Jacks (P16, P17)

SBC-IOT-IMX7 features two 3.5mm jacks. The analog audio signal pinouts are compatible with standard 3-pole audio cables. For additional details, please refer to section 3.4 of this document.

Table 14 P16 connector pin-out





Pin	Signal Name	Jack pin-out	Mating plug
1	AUDIO_GND		
2	NC		
3	AUDIO_OUT_R		
4	AUDIO_OUT_L		

Table 15 P17 connector pin-out

Pin	Signal Name	Jack pin-out	Mating plug
1	AUDIO_GND		
2	NC		
3	AUDIO_IN_R		
4	AUDIO_IN_L		

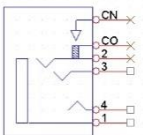
5.6 USB Host Connectors (P10, P11, P12 and P13)

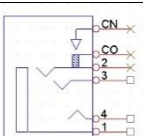
The SBC-IOT-IMX7 external USB2.0 host ports are available through four standard type-A USB connectors (P10, P11, P12, and P14). For additional details, please refer to section 3.5 of this document.

5.7 USB Console connector (P3)

The SBC-IOT-IMX7 serial debug console interface routed to micro USB connector P3. For more information, please refer to section 3.12 of this documents.

5.8 Gigabit Ethernet Connector (P15)

The SBC-IOT-IMX7 Gigabit Ethernet port 1 is routed to the standard RJ-45 connector (P15). For additional details, please refer to section 3.7.1 of this document.

5.9 POE Gigabit Ethernet Connector (P14)

The SBC-IOT-IMX7 Gigabit Ethernet port 2 is routed to the POE RJ-45 connector (P14). If SBC-IOT-IMX7 is attached to a POE PSE enabled network, the POE PSE network cable should be attached to P14 to power SBC-IOT-IMX7. For additional details, please refer to section 3.7.1 and 3.7.2 of this document.

5.10 RS-485 / CAN connector (P9)

The SBC-IOT-IMX7 RS-485 / CAN interface is routed to RJ11 connector P9. For more information refer to section 3.10.

Table 16 P9 connector pin-out

Pin	Signal Name	
	Without “Y” option	With “Y” option
1	485_TXN	CAN_VCC
2	GND	GND
3	485_TXP	CAN_H
4	485_RXP	CAN_L
5	GND	GND
6	485_RXN	CAN_GND

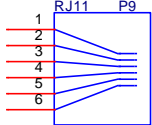

The connector is compatible with the RJ11 to DB-9 cable (CompuLab P/N ACC-CABDB9RJ11) available from CompuLab.

5.11 RS-232 connector (P8)

The SBC-IOT-IMX7 RS232 port is routed to the RS232 ultra-mini connector (P8). All signals are at RS232 levels. For more information refer to section 3.11.

Table 17 P8 connector pin-out

Pin	Signal Name	Pin	Signal Name
1	RS232_TXD	5	GND
2	NC	6	GND
3	RS232_RXD	7	NC
4	NC	8	GND

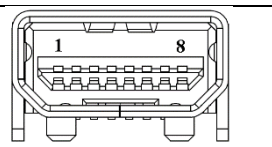

Table 18 P8 connector data

Manufacturer	Mfg. P/N	Mating connector
Wieson	G3169-500001	Wieson, P/N: 4306-5000

The connector is compatible with the serial adapter cable (CompuLab P/N ACCENC-ADPUMSER) available from CompuLab.

5.12 mPCIe Socket (P12)

The USB2 hub downstream port #3, PCIe and uSIM signals are routed to the mini-PCIe socket P12. The mini-PCIe connector can be used to host cellular data modem or any other mini-PCIe card.

Table 19 P12 connector pin-out

Pin	Signal Name	Pin	Signal Name
1	RESERVED	27	GND
2	3V3	28	1V5
3	NC	29	GND
4	GND	30	I2C5_SCL
5	NC	31	mPCIe_PET_N
6	1V5	32	I2C5_SDA
7	RESERVED	33	mPCIe_PET_P
8	SIM_VCC	34	GND
9	GND	35	GND
10	SIM_IO	36	USB_DM
11	mPCIe_REFCLKN	37	GND
12	SIM_CLK	38	USB_DP
13	mPCIe_REFCLKP	39	3V3
14	SIM_RST	40	GND
15	GND	41	3V3
16	SIM_VPP	42	NC
17	NC	43	NC
18	GND	44	NC
19	NC	45	NC
20	NC	46	NC
21	GND	47	NC
22	PERST	48	1V5
23	mPCIe_PER_N	49	NC
24	3V3	50	GND
25	mPCIe_PER_P	51	NC
26	GND	52	3V3

5.13 Power Button (SW1)

SBC-IOT-IMX7 power button SW1 controls the system power state. The table below describes the button functions.

Table 20 Power button functions

User action	System state	System behavior
Short press	OFF	Power ON
Mid press (> 5sec)	ON	Hardware shutdown
Short press	ON	TBD
Short press	Sleep	TBD

For additional details, please refer to section 4.1.2 of this document.

5.14 Embedded I/O connector

SBC-IOT-IMX7 embedded I/O connector P7 provides developers with additional set of IOs. The table below describes the connectors pinout.

Table 21 Embedded I/O Connector Interface Signals

P7 Pin #	Signal Name	Signal Description	i.MX7 CPU Pin Name	CL-SOM-iMX7 Pin #
1	PWR_ON	System power on signal	ONOFF	165
2	I2C3_SCL	I2C Serial Clock	GPIO1_IO08	43
3	I2C3_SDA	I2C Serial Data	GPIO1_IO09	49
4	GPIO3_18	GPIO	LCD_DAT13	77
5	GPIO3_17	GPIO	LCD_DAT12	79
6	SPI3_CLK	SPI clock signal	I2C2_SCL	69
7	SPI3_SIMO	Master data out; slave data in	I2C1_SDA	65
8	SPI3_SOMI	Master data in; slave data out	I2C1_SCL	63
9	SPI3_CS0	Chip select signal	I2C2_SDA	58
10	GPIO3_2	GPIO	LCD_HSYNC	7
11	GPIO3_3	GPIO	LCD_VSYNC	9
12	UART2_TX	Serial data transmit	LCD_ENABLE	3
13	UART2_RX	Serial data receive	LCD_CLK	5
14	GND	System Ground	N/A	GND

Table 22 P7 connector data

Manufacturer	Mfg. P/N
Aces	50224-01401-001

The connector is compatible with the I/O ribbon cable (CompuLab P/N ACCENC-CABFT14) available from CompuLab.

5.15 Indicator LED (DS1)

The table below describes SBC-IOT-IMX7 indicator LED.

Table 23 DS1 Dual Color LED description

Power state	Color	
	Green	Orange
On	On	OFF (Overlighted by Green)
Standby	Off	On

6 MECHANICAL DRAWINGS

SBC-IOT-iMX7 3D model is available for download at:

<http://www.compulab.com/products/sbcs/sbc-iot-imx7-nxp-i-mx-7-internet-of-things-single-board-computer/#devres>.

7 OPERATIONAL CHARACTERISTICS

7.1 Absolute Maximum Ratings

Table 24 Absolute Maximum Ratings

Parameter	Min	Typ.	Max	Unit
Main power supply voltage	-0.3	12	24	V
POE PSE	-60	48	60	V

NOTE: Stress beyond Absolute Maximum Ratings may cause permanent damage to the device.

7.2 Recommended Operating Conditions

Table 25 Recommended Operating Conditions

Parameter	Min	Typ.	Max	Unit
Main power supply voltage	9.5	12	24	V
POE PSE, polarity free	32	48	58	V