

# **SBC-IOT-IMX8PLUS**

---

Reference Guide



© 2023 CompuLab

No warranty of accuracy is given concerning the contents of the information contained in this publication. To the extent permitted by law, no liability (including a liability to any person because of negligence) will be accepted by CompuLab, its subsidiaries or employees for any direct or indirect loss or damage caused by omissions from or inaccuracies in this document.

CompuLab reserves the right to change details in this publication without notice.

Product and company names herein may be the trademarks of their respective owners.

CompuLab  
17 Ha Yetzira St., Yokneam Illit  
2069208, Israel

Tel: +972 (4) 8290100  
[www.compulab.com](http://www.compulab.com)  
Fax: +972 (4) 8325251

## Contents

<b>1</b>	<b>INTRODUCTION .....</b>	<b>6</b>
1.1	About This Document .....	6
1.2	Related Documents .....	6
<b>2</b>	<b>OVERVIEW.....</b>	<b>7</b>
2.1	Highlights.....	7
2.2	Specifications .....	8
<b>3</b>	<b>CORE SYSTEM COMPONENTS.....</b>	<b>10</b>
3.1	NXP i.MX8M Plus SoC.....	10
3.2	System Memory .....	10
3.2.1	DRAM.....	10
3.2.2	Primary Storage .....	10
3.3	WiFi and Bluetooth.....	10
3.4	Cellular and GPS.....	11
3.5	Ethernet .....	11
3.6	USB.....	12
3.6.1	USB3.0.....	12
3.6.2	USB2.0.....	12
3.7	CAN bus.....	12
3.8	Serial Debug Console.....	12
3.9	Display Output .....	12
3.10	USB Programming Port.....	12
3.11	I/O Expansion Socket.....	12
3.12	Industrial I/O (IE modules) .....	13
3.12.1	IE-RS485.....	13
3.12.2	IE-RS232.....	13
3.12.3	Digital inputs and outputs .....	14
<b>4</b>	<b>SYSTEM LOGIC.....</b>	<b>15</b>
4.1	Power Subsystem .....	15
4.1.1	Power Rails .....	15
4.1.2	Power Modes .....	15
4.1.3	RTC Back-Up Battery.....	15
4.2	Real-Time Clock .....	15
4.3	Hardware Watchdog.....	15
4.4	Trusted Platform Module .....	15
<b>5</b>	<b>INTERFACES AND CONNECTORS.....</b>	<b>16</b>
5.1	Connector Locations .....	16
5.1.1	Panel Connectors .....	16

5.1.2	Internal Connectors .....	17
5.2	DC Power Jack (J7).....	17
5.3	USB Host Connectors (J8, P17, P18) .....	17
5.4	Industrial I/O Connector (P8).....	18
5.5	Serial Debug Console (P5).....	18
5.6	RJ45 Ethernet Connectors (P13, P14).....	19
5.7	Mini-PCIe socket (P3) .....	19
5.8	Nano-SIM socket (U10).....	19
5.9	Expansion Connector (P19) .....	19
5.10	Indicator LEDs .....	21
5.11	Antenna Connectors .....	21
<b>6</b>	<b>MECHANICAL .....</b>	<b>22</b>
6.1	Heat Plate and Cooling Solutions .....	22
6.2	Mechanical Drawings.....	22
<b>7</b>	<b>OPERATIONAL CHARACTERISTICS.....</b>	<b>23</b>
7.1	Absolute Maximum Ratings .....	23
7.2	Recommended Operating Conditions .....	23
7.3	Typical Power Consumption.....	23

**Table 1 Document Revision Notes**

Date	Description
July 2022	<ul style="list-style-type: none"><li>• First release</li></ul>
Nov 2023	<ul style="list-style-type: none"><li>• Added description of 2<sup>nd</sup> CAN port in sections 3.7 and 5.4</li><li>• Added TPM add-on description in section 4.4</li><li>• Fixed specifications typo</li><li>• Added typical power consumption in section 7.3</li></ul>

# 1 INTRODUCTION

---

## 1.1 About This Document

This document is part of a set of documents providing information necessary to operate and program Compulab SBC-IOT-IMX8PLUS.

## 1.2 Related Documents

For additional information not covered in this manual, please refer to the documents listed in Table 2.

**Table 2 Related Documents**

Document	Location
SBC-IOT-IMX8PLUS resources	<a href="https://www.compulab.com/products/sbcs/sbc-iot-imx8plus-nxp-imx8m-plus-internet-of-things-single-board-computer/#devres">https://www.compulab.com/products/sbcs/sbc-iot-imx8plus-nxp-imx8m-plus-internet-of-things-single-board-computer/#devres</a>

## 2 OVERVIEW

---

### 2.1 Highlights

- NXP i.MX8M-Plus CPU, quad-core Cortex-A53
- Up to 8GB RAM and 128GB eMMC
- LTE/4G modem, WiFi 802.11ax, Bluetooth 5.3
- 2x LAN, USB3.0, 2x USB2.0 and CAN bus
- Up-to 3x RS485 | RS232 and digital I/O
- Secure boot and Hardware Watchdog
- Designed for reliability and 24/7 operation
- Wide temperature range of -40C to 80C
- Input voltage range of 8V to 36V and PoE client
- Debian Linux and Yocto Project

## 2.2 Specifications

**Table 3 CPU Core, RAM, and Storage**

Feature	Specifications
CPU	NXP i.MX8M Plus Quad, quad-core ARM Cortex-A53, 1.8GHz
NPU	AI/ML Neural Processing Unit, up to 2.3 TOPS
Real-Time Co-processor	ARM Cortex-M7, 800Mhz
RAM	1GB – 8GB, LPDDR4
Primary storage	16GB - 128GB eMMC flash, soldered on-board

**Table 4 Network**

Feature	Specifications
LAN	2x 1000Mbps Ethernet portx, RJ45 connectors
WiFi and Bluetooth	802.11ax WiFi and Bluetooth 5.3 BLE Implemented with Intel WiFi 6E AX210 module 2x 2.4GHz / 5GHz rubber duck antennas
Cellular	4G/LTE CAT4 cellular module, Quectel EC25-E/A Cellular rubber duck antenna SIM card socket
GNSS	GPS Implemented with Quectel EC25 module

**Table 5 Display and Graphics**

Feature	Specifications
Display Output	DVI-D, up to 1080p60
GPU and Video	GC7000UL GPU 1080p60 HEVC/H.265, AVC/H.264 * only with C1800QM CPU option

**Table 6 I/O and System**

Feature	Specifications
USB	2x USB2.0 ports, type-A connectors (back panel)
	1x USB3.0 port, type-A connector (front panel)
RS485 / RS232	Up-to 3x RS485 (half-duplex)   RS232 ports Isolated, terminal-block connector
CAN bus	Up to 2x CAN bus port Isolated, terminal-block connector
Digital I/O	4x digital outputs + 4x digital inputs Isolated, 24V compliant with EN 61131-2, terminal-block connector
Debug	1x serial console via UART-to-USB bridge, micro-USB connector
	Support for NXP SDP/UUU protocol, micro-USB connector
Expansion	Expansion connector for add-on boards LVDS, SDIO, USB, SPI, I2C, GPIOs
Security	Secure boot, implemented with i.MX8M Plus HAB module
LEDs	2x general purpose dual-color LEDs
RTC	Real time clock operated from on-board coin-cell battery
Watchdog	Hardware watchdog
PoE	Support for PoE (powered device)



**Table 7 Electrical, Mechanical and Environmental**

Supply Voltage	Unregulated 8V to 36V
Dimensions	132 x 84 x 25mm
Heat-plate	Aluminum heat-plate, 130mm x 80mm * only with "H" configuration option
Cooling	Passive cooling, fanless design
Weight	450 gram
MTTF	200,000 hours
Operation temperature	Commercial: 0° to 60° C Extended: -20° to 60° C Industrial: -40° to 80° C

## 3 CORE SYSTEM COMPONENTS

### 3.1 NXP i.MX8M Plus SoC

The i.MX8M Plus processors feature advanced implementation of a quad ARM® Cortex®-A53 core, which operates at speeds of up to 1.8 GHz. A general purpose Cortex®-M7 core processor enables low-power processing.

**Figure 1 i.MX8M Plus Block Diagram**

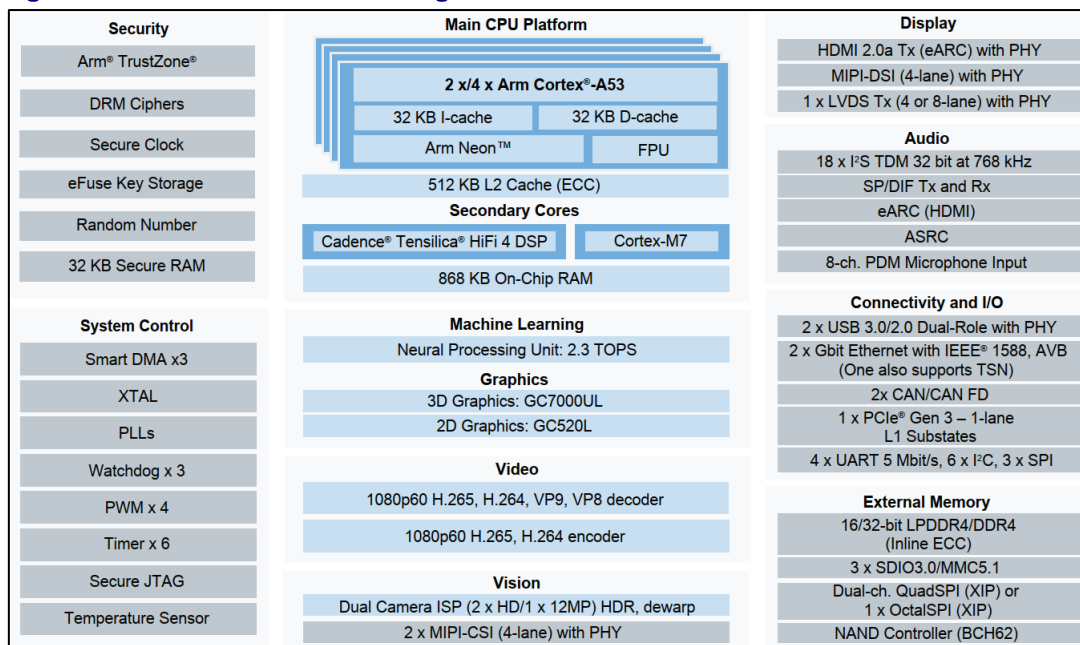

### 3.2 System Memory

#### 3.2.1 DRAM

SBC-IOT-IMX8PLUS is available with up to 8GB of on-board LPDDR4 memory.

#### 3.2.2 Primary Storage

SBC-IOT-IMX8PLUS features up to 128GB of soldered on-board eMMC memory for storing the bootloader and operating system (Kernel and root filesystem). The remaining eMMC space is used to store general-purpose (user) data.

### 3.3 WiFi and Bluetooth

SBC-IOT-IMX8PLUS can be optionally assembled with the Intel WiFi 6 AX210 module providing 2x2 WiFi 802.11ax and Bluetooth 5.3 interfaces.

AX210 module is installed into M.2 socket (P22).

WiFi and Bluetooth antenna connections are available via two on-board MHF4 connectors.

SBC-IOT-IMX8PLUS is supplied with two MHF4-to-RP-SMA cables and two 2.4GHz / 5GHz rubber duck antennas.

### 3.4 Cellular and GPS

SBC-IOT-IMX8PLUS cellular interface is implemented with a mini-PCIe cellular modem module and a nano-SIM socket. To set up SBC-IOT-IMX8PLUS for cellular functionality, install an active SIM card into nano-SIM socket U10. The cellular module should be installed into mini-PCIe socket P3.

The cellular modem module also implements GNSS / GPS.

Modem antenna connections are available via on-board MHF connectors. SBC-IOT-IMX8PLUS is supplied with two MHF-to-SMA cables and one cellular rubber-duck antenna.

CompuLab supplies SBC-IOT-IMX8PLUS with the following cellular modem options:

- 4G/LTE CAT4 cellular module, Quectel EC25-E (EU bands)
- 4G/LTE CAT4 cellular module, Quectel EC25-A (US bands)

**Figure 2 cellular modem and SIM card sockets**

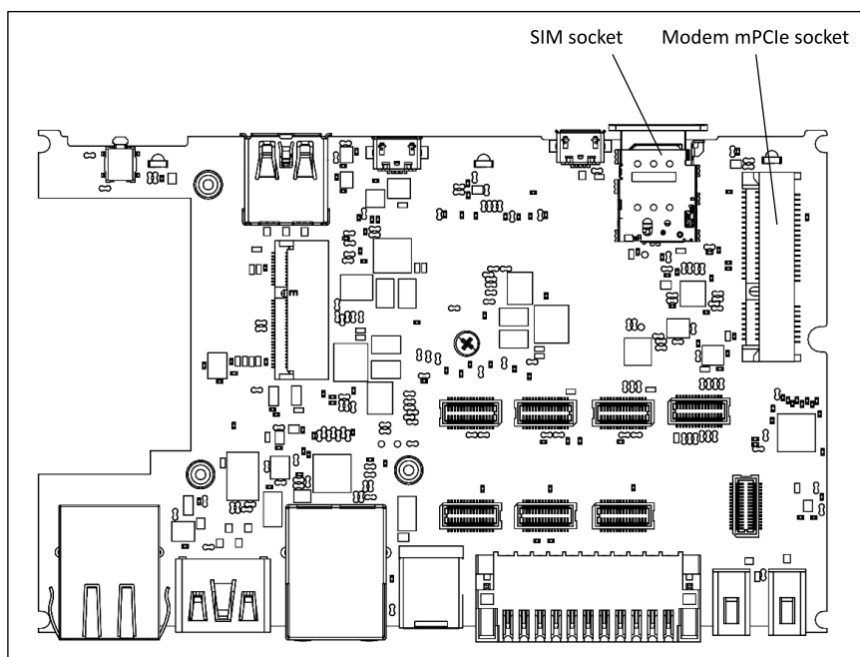

### 3.5 Ethernet

SBC-IOT-IMX8PLUS incorporates two Ethernet ports implemented with i.MX8M Plus internal MACs and two Realtek RTL8211 PHYs

ETH1 is available on connector P13; ETH2 is available on connector P14.

ETH2 port features optional POE 802.3af powered device capability.

---

**NOTE: ETH2 port features PoE powered device capability only when the unit is ordered with the ‘POE’ configuration option.**

---

## 3.6 USB

### 3.6.1 USB3.0

SBC-IOT-IMX8PLUS features one USB3.0 host port routed to front panel USB connector J8. USB3.0 port is implemented directly with the native i.MX8M Plus port.

### 3.6.2 USB2.0

SBC-IOT-IMX8PLUS features two external USB2.0 host ports. The ports are routed to back panel USB connectors P17 and P18. All USB2.0 ports are implemented with MicroChip USB2514 USB hub.

## 3.7 CAN bus

SBC-IOT-IMX8PLUS features up to 2 CAN 2.0B ports implemented with i.MX8M Plus CAN controller.

CAN bus signals are routed to industrial I/O connector P8. For pin-out details please refer to section 5.4.

---

**NOTE: One CAN bus port is always available. Additional (2<sup>nd</sup>) CAN bus port occupies one of the industrial I/O (IE) slots and is only available when SBC-IOT-IMX8PLUS is ordered with the FCCAN ordering option.**

---

## 3.8 Serial Debug Console

SBC-IOT-IMX8PLUS features a serial debug console via UART-to-USB bridge over micro USB connector. CP2104 UART-to-USB bridge is interfaced with i.MX8M Plus UART port. CP2104 USB signals are routed to micro USB connector P20, located on the front panel.

## 3.9 Display Output

SBC-IOT-IMX8PLUS features DVI-D interface routed to standard HDMI connector. Display output interface support resolutions of up-to 1920 x 1080.

## 3.10 USB Programming Port

SBC-IOT-IMX8PLUS features a USB programming interface that can be used for device recovery using the NXP UUU utility.

USB programming interface is routed to the front panel connector P16.

When a host PC is connected with a USB cable to the USB programming connector, SBC-IOT-IMX8PLUS disables normal boot from eMMC and enters Serial Downloader boot mode.

## 3.11 I/O Expansion Socket

SBC-IOT-IMX8PLUS expansion interface is available on M.2 Key-E socket P12. The expansion connector allows integration of custom I/O add-on boards into SBC-IOT-IMX8PLUS. The expansion connector features embedded interfaces such as LVDS, I2C, SPI, USB and SDIO.

## 3.12 Industrial I/O (IE modules)

SBC-IOT-IMX8PLUS features 4 industrial I/O (IE) slots that can be fitted with up-to 4 different I/O modules. Each IE slot is isolated from SBC-IOT-IMX8PLUS.

I/O slots A,B,C can be fitted with RS232 or RS485 I/O modules. I/O slot D can only be fitted with a digital I/O (4x DI, 4x DO) module.

**Table 8 Industrial I/O – functions and ordering codes**

	I/O slot A	I/O slot B	I/O slot C	I/O slot D
RS-232 (2-wire)	FARS2	FBRS2	F CRS2	-
RS-485 (half-duplex)	FARS4	FBRS4	F CRS4	-
Digital I/O(4x DI, 4x DO)	-	-	-	FDIO

Combination examples:

- For 2x RS485 the ordering code will be SBC-IOTIMX8PLUS-...-FARS4-FBRS4-...
- For 1x RS232 + 1x RS485 + digital I/O the ordering code will be SBC-IOTIMX8PLUS-...-FARS2-FBRS4-FDIO-...

Certain I/O combinations may also be implemented with on-board SMT components.

Industrial I/O signals are routed to a 2x11 terminal block on the SBC-IOT-IMX8PLUS back panel. For connector pin-out please refer to section 5.4.

### 3.12.1 IE-RS485

RS485 function is implemented with MAX13488 transceiver interfaced with i.MX8M Plus UART ports. Key characteristics:

- 2-wire, half-duplex
- Galvanic isolation from the main unit
- Programmable baud rate of up to 3Mbps
- Software controlled 120ohm termination resistor

### 3.12.2 IE-RS232

RS232 function is implemented with MAX3221 (or compatible) transceiver interfaced with i.MX8M Plus UART ports. Key characteristics:

- RX/TX only
- Galvanic isolation from the main unit
- Programmable baud rate of up to 250kbps

### 3.12.3 Digital inputs and outputs

Four digital inputs are implemented with the CLT3-4B digital termination following EN 61131-2. Four digital outputs are implemented with the VNI4140K solid-state relay following EN 61131-2. Key characteristics:

- External supply voltage up to 24V
- Galvanic isolation from the main unit and other I/O modules
- Digital outputs maximal output current – 0.5A per channel

**Figure 3 Digital output – typical wiring example**

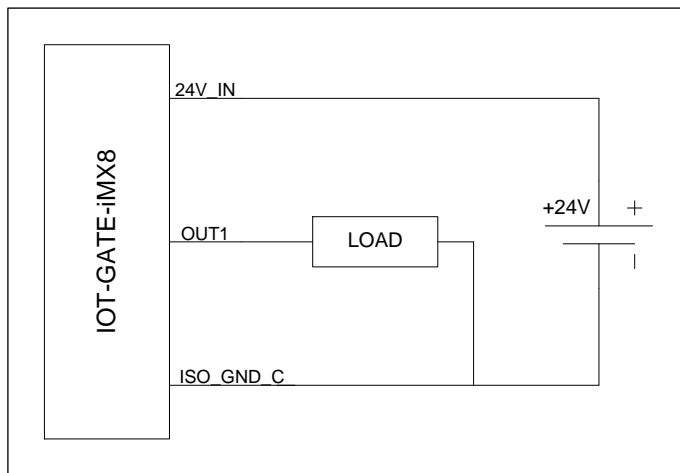

**Figure 4 Digital input – typical wiring example**

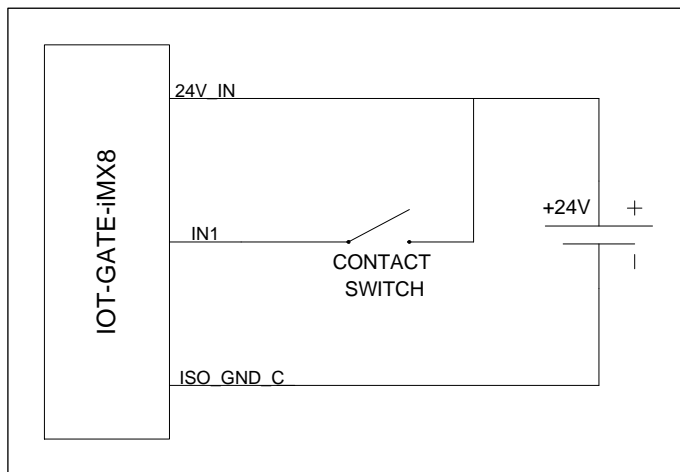

## 4 SYSTEM LOGIC

---

### 4.1 Power Subsystem

#### 4.1.1 Power Rails

SBC-IOT-IMX8PLUS is powered with a single power rail with an input voltage range of 8V to 36V. When SBC-IOT-IMX8PLUS is assembled with the “POE” option it can also be powered through ETH2 connector from a 802.3at Type 1 PoE source.

#### 4.1.2 Power Modes

SBC-IOT-IMX8PLUS supports three hardware power modes.

**Table 9 Power modes**

Power Mode	Description
ON	All internal power rails are enabled. Mode entered automatically when the main power supply is connected.
OFF	CPU core power rails are off. All peripheral power rails are off.
Sleep	DRAM is maintained in self-refresh. Most CPU core power rails are off. Most of the peripheral power rails are off.

#### 4.1.3 RTC Back-Up Battery

SBC-IOT-IMX8PLUS features a 120mAh coin cell lithium battery, which maintains the on-board RTC whenever the main power supply is not present.

### 4.2 Real-Time Clock

SBC-IOT-IMX8PLUS RTC is implemented with the AM1805 real-time clock (RTC) chip. The RTC is connected to the i.MX8M Plus SoC using I2C interface at address 0xD2/D3. SBC-IOT-IMX8PLUS back-up battery keeps the RTC running to maintain clock and time information whenever the main power supply is not present.

### 4.3 Hardware Watchdog

SBC-IOT-IMX8PLUS watchdog function is implemented with the i.MX8M Plus watchdog.

### 4.4 Trusted Platform Module

SBC-IOT-IMX8PLUS can be optionally (ordering code “FXTPM”) assembled with a TPM add-on board installed into the expansion connector. TPM implemented with Infineon SLB9670.

---

**NOTE: TPM add-on uses the expansion connector and cannot be combined with any other add-on board.**

---

## 5 INTERFACES AND CONNECTORS

### 5.1 Connector Locations

#### 5.1.1 Panel Connectors

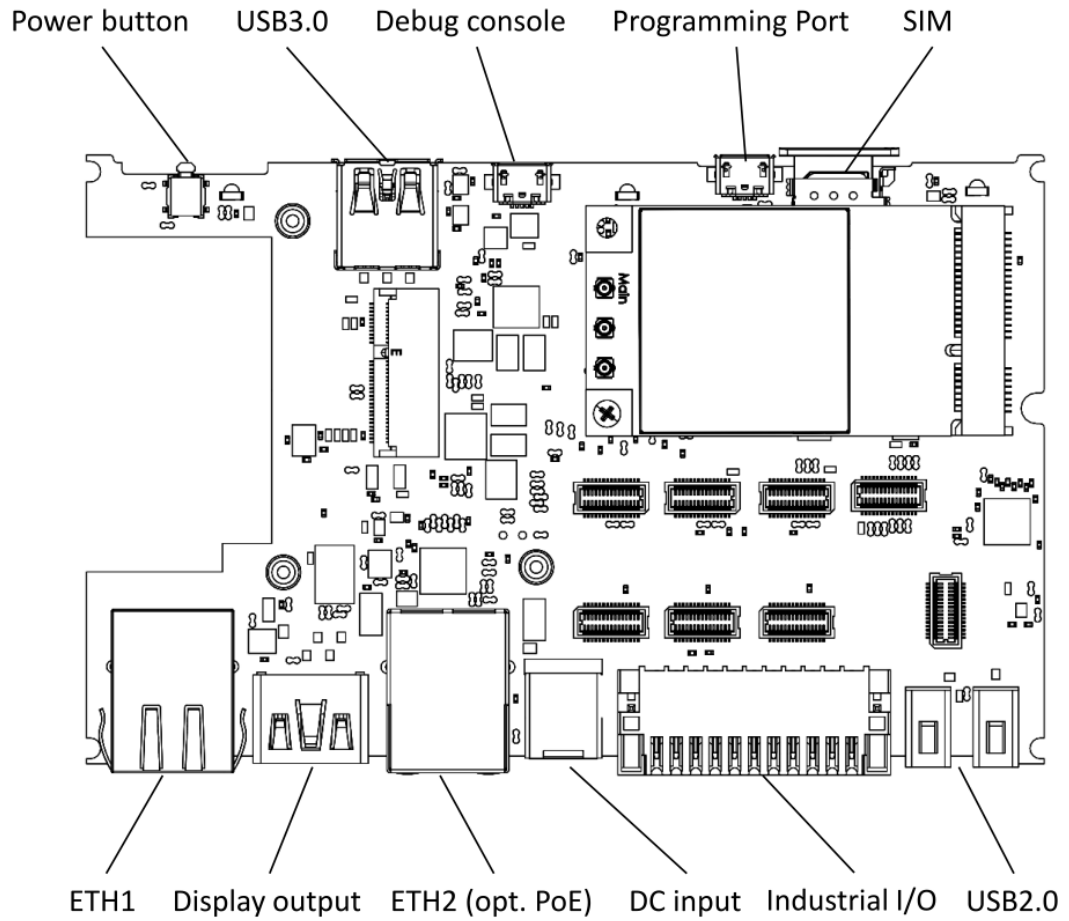



### 5.1.2 Internal Connectors

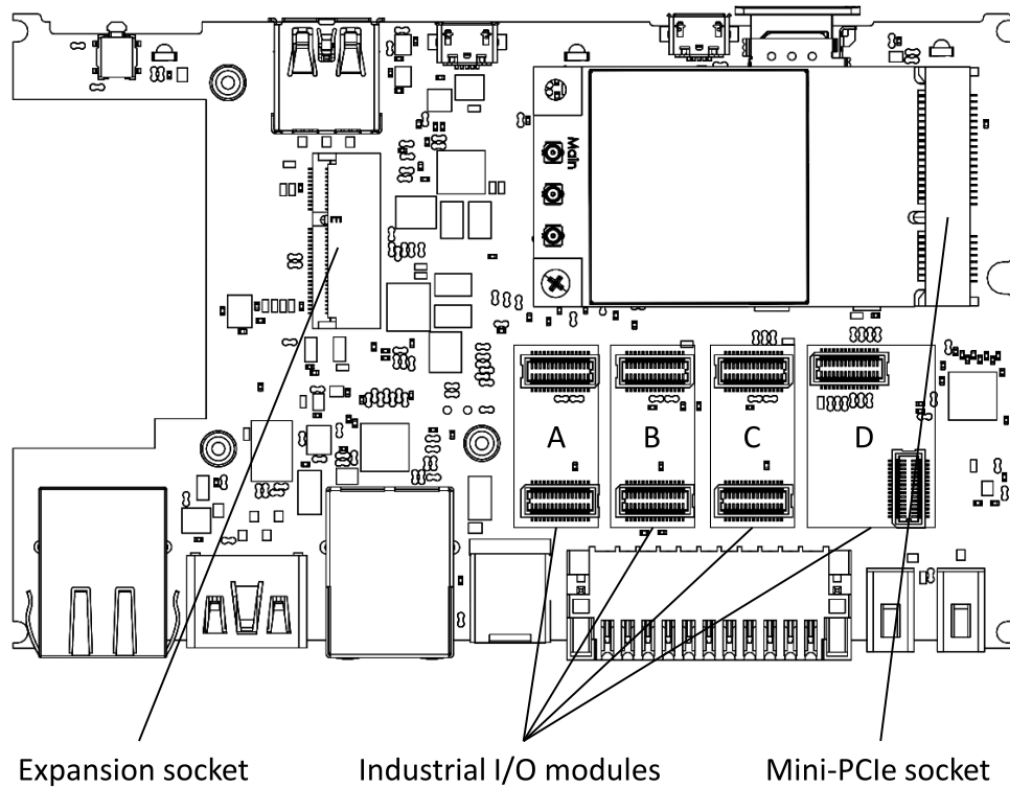

### 5.2 DC Power Jack (J7)

DC power input connector.

**Table 10 DC jack connector pin-out**

Pin	Signal Name	
1	DC IN	
2	GND	

**Table 11 DC jack connector data**

Manufacturer	Mfg. P/N
Contact Technology	DC-081HS(-2.5)

The connector is compatible with the SBC-IOT-IMX8PLUS AC PSU and IOTG-ACC-CABDC DC cable available from CompuLab.

### 5.3 USB Host Connectors (J8, P17, P18)

SBC-IOT-IMX8PLUS USB3.0 host port is available through standard type-A USB3 connector J8.

SBC-IOT-IMX8PLUS USB2.0 host ports are available through two standard type-A USB connectors P17 and P18.

For additional details, please refer to section 3.6 of this document.

## 5.4 Industrial I/O Connector (P8)

SBC-IOT-IMX8PLUS industrial I/O signals are routed to terminal block P8. Pin-out is determined by the I/O modules configuration. For additional details please refer to section 3.12.

**Table 12 Industrial I/O add-on connector pin-out**

I/O module	Pin	Signal Name	Isolation Power Domain
A	1	RS232_TXD / RS485_POS	1
-	2	CAN_L	1
A	3	RS232_RXD / RS485_NEG	1
-	4	CAN_H	1
A	5	ISO_GND_1	1
B	6	RS232_RXD / RS485_NEG	2
B	7	RS232_TXD / RS485_POS	2
B	8	ISO_GND_2	2
D	9	IN0	3
D	10	IN1	3
D	11	IN2	3
C	12	RS232_TXD / RS485_POS / CAN_H	3
D	13	IN3	3
C	14	RS232_RXD / RS485_NEG / CAN_L	3
D	15	OUT0	3
D	16	OUT1	3
D	17	OUT3	3
D	18	OUT2	3
D	19	24V_IN	3
D	20	24V_IN	3
C/D	21	ISO_GND_3	3
C/D	22	ISO_GND_3	3

**Table 13 Industrial I/O add-on connector data**

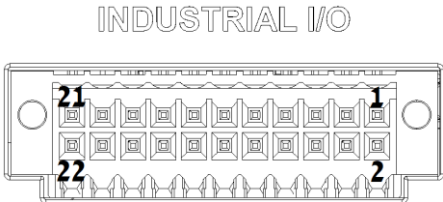
Connector type	Pin numbering
22-pin dual-row plug with push-in spring connections Locking: screw flange Pitch: 2.54 mm Wire cross-section: AWG 20 – AWG 30  Connector P/N: Kunacon HGCH25422500K Mating connector P/N: Kunacon PDFD25422500K  NOTE: CompuLab supplies the mating connector with the gateway unit	

## 5.5 Serial Debug Console (P5)

SBC-IOT-IMX8PLUS serial debug console interface is routed to micro USB connector P20. For additional information, please refer to section 3.8 of this documents.

## 5.6 RJ45 Ethernet Connectors (P13, P14)

SBC-IOT-IMX8PLUS Ethernet port ETH1 is routed to RJ45 connector P13. SBC-IOT-IMX8PLUS Ethernet port ETH2 is routed to RJ45 connector P14. For additional details, please refer to section 3.5 of this document.

## 5.7 Mini-PCIe socket (P3)

SBC-IOT-IMX8PLUS features one mini-PCIe socket P3 mainly intended for cellular modem modules. P3 implements USB and SIM interfaces. Socket P3 does not implement PCIe signals.

## 5.8 Nano-SIM socket (U10)

The nano-uSIM socket (U10) is connected to mini-PCIe socket P3.

## 5.9 Expansion Connector (P19)

SBC-IOT-IMX8PLUS expansion interface is available on M.2 Key-E socket with a custom pin-out P19. The expansion connector allows to integrate custom I/O add-on boards into SBC-IOT-IMX8PLUS. The following table outlines the connector pin-out and available pin functions.

**Table 14** Expansion connector pin-out

Pin	Signal name	Description	Pin	Signal name	Description
2	VCC_3.3V	Power output 3.3V	1	GND	
4	VCC_3.3V	Power output 3.3V	3	USB_DP	Optional multiplexed USB2 from USB Hub
6	VCC_5V	Power output 5V	5	USB_DN	Optional multiplexed USB2 from USB Hub
8	VCC_5V	Power output 5V	7	GND	
10	VBATA_IN	Power input (8V - 36V)	9	I2C6_SCL	I2C6_SCL / PWM4_OUT / GPIO3_IO19 (1.8V voltage level)
12	VBATA_IN	Power input (8V - 36V)	11	I2C6_SDA	I2C6_SDA / PWM3_OUT / GPIO3_IO20 (1.8V voltage level)
14	VBATA_IN	Power input (8V - 36V)	13	GND	
16	EXT_PWRB TNn	ON/OFF input	15	ECSPI2_SS0	ECSPI2_SS0 / GPIO5_IO13 (3.3V voltage level)
18	GND		17	ECSPI2_MISO	ECSPI2_MISO / GPIO5_IO12 (3.3V voltage level)
20	EXT_RESET	Reset input	19	GND	
22	RESERVED		21	ECSPI2_SCLK	ECSPI2_SCLK / GPIO5_IO10 (3.3V voltage level)
24	NC	Key E notch	23	ECSPI2_MOSI	ECSPI2_MOSI / GPIO5_IO11 (3.3V voltage level)
26	NC	Key E notch	25	NC	Key E notch
28	NC	Key E notch	27	NC	Key E notch
30	NC	Key E notch	29	NC	Key E notch
32	GND		31	NC	Key E notch
34	I2C5_SDA	I2C5_SDA / PWM1_OUT / GPIO3_IO25 (3.3V/1.8V voltage level)	33	GND	
36	I2C5_SCL	I2C5_SCL / PWM2_OUT / GPIO3_IO21 (3.3V/1.8V voltage level)	35	JTAG_TMS	SoC JTAG

38	GND		37	JTAG_TDI	SoC JTAG
40	JTAG_TCK	SoC JTAG	39	GND	
42	GND		41	JTAG_MOD	SoC JTAG
44	RESERVED		43	JTAG_TDO	SoC JTAG
46	SD2_DATA2	SD2_DATA2 / GPIO2_IO17 (3.3V/1.8V voltage level)	45	GND	
48	SD2_CLK	SD2_CLK / GPIO2_IO13 (3.3V/1.8V voltage level)	47	LVDS_CLK_P	LVDS output clock
50	SD2_DATA3	SD2_DATA3 / GPIO2_IO18 (3.3V/1.8V voltage level)	49	LVDS_CLK_N	LVDS output clock
52	SD2_CMD	SD2_CMD / GPIO2_IO14 (3.3V/1.8V voltage level)	51	GND	
54	SD2_DATA0	SD2_DATA0 / GPIO2_IO15 (3.3V/1.8V voltage level)	53	LVDS_D3_N	LVDS output data
56	GND		55	LVDS_D3_P	LVDS output data
58	SD2_DATA1	SD2_DATA1 / GPIO2_IO16 (3.3V/1.8V voltage level)	57	GND	
60	SD2_nRST	SD2_nRST / GPIO2_IO19 (3.3V/1.8V voltage level)	59	LVDS_D2_N	LVDS output data
62	GND		61	LVDS_D2_P	LVDS output data
64	RESERVED		63	GND	
66	GND		65	LVDS_D1_N	LVDS output data
68	RESERVED		67	LVDS_D1_P	LVDS output data
70	RESERVED		69	GND	
72	VCC_3.3V	Power output 3.3V	71	LVDS_D0_P	LVDS output data
74	VCC_3.3V	Power output 3.3V	73	LVDS_D0_N	LVDS output data
			75	GND	

## 5.10 Indicator LEDs

The tables below describe SBC-IOT-IMX8PLUS indicator LEDs.

**Table 15 Power LED**

Main power connected	LED state
Yes	On
No	Off

General purpose LEDs are controlled by SoC GPIOs.

**Table 16 User LED #1**

GP5_IO05 state	LED state
Low	Off
High	Red

**Table 17 User LED #2**

GP5_IO01 state	GP4_IO28 state	LED state
Low	Low	Off
Low	High	Green
High	Low	Red
High	High	Yellow

## 5.11 Antenna Connectors

SBC-IOT-IMX8PLUS features up-to four connectors for external antennas.

**Table 18 Default antenna connector assignment**

Connector Name	Function	Connector Type
WLAN-A / BT	WiFi/BT main antenna	RP-SMA
WLAN-B	WiFi auxilalry antenna	RP-SMA
WWAN	LTE main antenna	SMA
AUX	GPS antenna	SMA

## 6 MECHANICAL

---

### 6.1 Heat Plate and Cooling Solutions

SBC-IOT-IMX8PLUS is provided with an optional heat-plate assembly. The heat-plate is designed to act as a thermal interface and should usually be used in conjunction with a heat-sink or an external cooling solution. A cooling solution must be provided to ensure that under worst-case conditions the temperature on any spot of the heat-spreader surface is maintained according to the SBC-IOT-IMX8PLUS temperature specifications. Various thermal management solutions can be used, including active and passive heat dissipation approaches.

### 6.2 Mechanical Drawings

SBC-IOT-IMX8PLUS 3D model is available for download at:

<https://www.compulab.com/products/sbcs/sbc-iot-imx8plus-nxp-i-mx8m-plus-internet-of-things-single-board-computer/#devres>

## 7 OPERATIONAL CHARACTERISTICS

### 7.1 Absolute Maximum Ratings

**Table 19 Absolute Maximum Ratings**

Parameter	Min	Max	Unit
Main power supply voltage	-0.3	40	V

**NOTE:** Stress beyond Absolute Maximum Ratings may cause permanent damage to the device.

### 7.2 Recommended Operating Conditions

**Table 20 Recommended Operating Conditions**

Parameter	Min	Typ.	Max	Unit
Main power supply voltage	8	12	36	V

### 7.3 Typical Power Consumption

**Table 21 SBC-IOT-IMX8PLUS Typical Power Consumption**

Use case	Use case description	Current	Power
Linux idle, headless	Linux up, Ethernet up, no display, no activity	200mA	2.4W
Linux idle, with display	Linux up, ethernet up, display connected, no activity	250mA	3.0W
Wi-Fi or Ethernet data transfer	Linux up, no display, active ethernet or Wi-Fi data transmission	300mA	3.6W
Cellular modem data transfer	Linux up, no display, active modem data transmission	400mA	4.8W
Heavy mixed load without cellular activity	CPU and memory stress-test + Wi-Fi running + Bluetooth running + Ethernet activity + LEDs	450mA	5.4W
Heavy mixed load with active cellular modem data transfer	CPU and memory stress-test + active modem data transmission	650mA	7.8W

Power consumption has been measured with the following setup:

1. Configuration - SBC-IOTIMX8PLUS--C1800QM-D4-N32-WB-JEC25E-FARS4-FBRS2-FDIO-POE-PS-XL
2. Standard SBC-IOTIMX8PLUS 12VDC PSU
3. Software stack - stock Debian for SBC-IOTIMX8PLUS v1.1