

IOT-DIN-IMX8PLUS

Reference Guide



© April 2024 CompuLab

No warranty of accuracy is given concerning the contents of the information contained in this publication. To the extent permitted by law, no liability (including a liability to any person because of negligence) will be accepted by CompuLab, its subsidiaries or employees for any direct or indirect loss or damage caused by omissions from or inaccuracies in this document.

CompuLab reserves the right to change details in this publication without notice.

Product and company names herein may be the trademarks of their respective owners.

CompuLab
17 Ha Yetzira St., Yokneam Illit
2069208, Israel

Tel: +972 (4) 8290100

www.compulab.com

Fax: +972 (4) 8325251

Contents

1	INTRODUCTION	6
1.1	About This Document	6
1.2	Related Documents	6
2	OVERVIEW.....	7
2.1	Highlights.....	7
2.2	Specifications	8
2.3	IOT-DIN-IMX8PLUS Part Number	9
3	CORE SYSTEM COMPONENTS.....	10
3.1	NXP i.MX8M Plus SoC	10
3.2	System Memory	10
3.2.1	DRAM.....	10
3.2.2	Primary Storage	10
3.3	Cellular and GPS.....	11
3.4	Ethernet.....	11
3.5	Serial Debug Console.....	11
3.6	USB Programming Port	11
3.7	Industrial I/O Terminal Block.....	11
3.7.1	CAN Bus.....	12
3.7.2	RS485.....	12
3.7.3	RS232.....	12
3.7.4	Digital inputs (x2) and outputs (x2).....	12
4	I/O EXPANSION MODULES.....	14
4.1	I/O Expansion Modules Interconnection	14
4.2	Supported I/O Expansion Modules	14
5	SYSTEM LOGIC.....	15
5.1	Power Subsystem	15
5.1.1	Power Rails	15
5.1.2	Power Modes	15
5.1.3	RTC Back-Up Battery.....	15
5.2	Real-Time Clock	15
5.3	Hardware Watchdog	15
5.4	Trusted Platform Module	15
6	INTERFACES AND CONNECTORS.....	16
6.1	Connector Locations	16
6.1.1	Front Panel	16
6.1.2	Bottom Panel.....	17
6.2	DC Power Connector	17

6.2.1	Remote Power CNTL Input	18
6.2.2	Typical Connection Schematic	18
6.3	USB Host Connector.....	18
6.4	Industrial I/O Connector	19
6.5	Serial Debug Console.....	19
6.6	RJ45 Ethernet Connectors.....	20
6.7	SIM card socket	20
6.8	Indicator LEDs	20
6.9	Antenna Connectors	20
7	MECHANICAL DRAWINGS.....	21
8	OPERATIONAL CHARACTERISTICS.....	22
8.1	Absolute Maximum Ratings	22
8.2	Recommended Operating Conditions	22
8.3	Typical Power Consumption.....	22

Table 1 Document Revision Notes

Date	Description
May 2024	<ul style="list-style-type: none"><li data-bbox="564 365 687 389">• First release

Please check for a newer revision of this manual at the Compulab website.
<https://www.compulab.com>. Compare the revision notes of the updated manual from the website with those of the printed or electronic version you have.

1 INTRODUCTION

1.1 About This Document

This document is part of a set of documents providing information necessary to operate and program Compulab IOT-DIN-IMX8PLUS.

1.2 Related Documents

For additional information not covered in this manual, please refer to the documents listed in Table 2.

Table 2 Related Documents

Document	Location
IOT-DIN-IMX8PLUS resources	https://www.compulab.com/products/iot-gateways/iot-din-imx8plus-industrial-iot-gateway/#devres

2 OVERVIEW

2.1 Highlights

IOT-DIN-IMX8PLUS is an industrial IoT gateway with integrated DIN rail latch mechanism and modular I/O Expansion modules.

- CPU: NXP i.MX8M Plus, quad-core Cortex-A53, 1.8GHz
- DRAM : Up to 8GB RAM ; Storage: Up to 128GB eMMC
- Built-in interfaces: 2x LAN, USB3.0, TPM2.0, RS485, RS232, CAN bus, 2x DI + 2x DO
- Optional LTE/4G global modem
- Stackable I/O Expansion modules:
 - Serial – up to 12x RS485 | RS232
 - Digital I/O – up-to 32x DO + 32x DI
 - ADC – up to 8 channels
 - Wireless: 802.11ax WiFi and Bluetooth 5.3 BLE
- Several temperature rating options:
 - Commercial: 0°C to 50°C
 - Industrial: -30°C to 70°C
- Operating systems: Debian Linux; Yocto Project; Balena OS

2.2 Specifications

The "Option" column specifies the IOT-DIN-IMX8PLUS configuration option required to have the feature.

"+" means that the feature is always available.

Table 3 Features and Configuration options.

Feature	Description	Option
CPU Core and Graphics		
CPU	NXP i.MX8M Plus QuadLite, quad-core ARM Cortex-A53, 1.8GHz	C1800Q
	NXP i.MX8M Plus Quad, quad-core ARM Cortex-A53, 1.8GHz	C1800QM
NPU	AI/ML Neural Processing Unit, up to 2.3 TOPS	C1800QM
Real-Time Co-processor	ARM Cortex-M7, 800Mhz	+
Memory and Storage		
RAM	1GB – 8GB, LPDDR4	D
Storage	eMMC flash, soldered on board 16GB - 64GB	N
Network		
LAN	2x GBit Ethernet, RJ45 connectors	+
Cellular	4G/LTE CAT4 cellular module, Quectel EG25G Worldwide LTE, UMTS/HSPA+ and GSM/GPRS/EDGE coverage	JEG25G
	SIM card Socket	+
I/O		
USB	1x USB3.0 port, type-A connector	+
Serial	1x RS485, two-wire port Isolated, terminal-block connector	+
	1x RS232, Rx/Tx Isolated, terminal-block connector	
CAN bus	1x CAN bus port Isolated, terminal-block connector	+
Digital I/O	2x digital outputs + 2x digital inputs Isolated, 24V compliant with EN 61131-2, terminal-block connector	+
Debug	Serial console via UART-to-USB bridge, micro-USB connector	+
	NXP SDP programming port, micro-USB connector	+
I/O Expansion modules		
Wireless	802.11ax WiFi and Bluetooth 5.3 BLE Implemented with Intel WiFi 6E AX210 module 2x RP-SMA connectors Stacking restrictions: one wireless module	FAWB
RS485	4x RS485, two-wire Isolated, terminal-block connector Stacking restrictions: up-to 3 RS485 RS232 modules	FxRS4
RS232	4x RS232, Rx/Tx Isolated, terminal-block connector Stacking restrictions: up-to 3 RS485 RS232 modules	FxRS2
Digital I/O	8x digital outputs + 8x digital inputs Isolated, 24V compliant with EN 61131-2, terminal-block connector Stacking restrictions: up-to 4 digital I/O modules	FxDI808
ADC	8x analog inputs, 0...10V / 4...20mA Isolated, terminal block connector Stacking restrictions: one ADC module	FxADC
System		
RTC	Real time clock operated from on-board coin-cell battery	+

Feature	Description	Option
Watchdog	Hardware Watchdog	+
Security	Secure boot, implemented with i.MX8M Plus HAB module	+
	TPM 2.0, Infineon SLB9673	
Indicators	2x programmable dual-color LEDs	+

Table 4 Electrical, Mechanical and Environmental

Electrical Specifications	
Power Supply	12V-24V DC (-20%/+20%) Reverse voltage protection
Power consumption	2.5 - 8 W, depending on system load and device configuration
Mechanical Specifications	
Housing type	DIN rail housing (for DIN rail version EN 50022)
Housing material	ABS/PC high endurance
Dimensions	Gateway – 110 x 30 x 95 mm I/O Expansion module – 110 x 20 x 95 mm
Cooling	Passive cooling, fanless design
Weight	Gateway – 0.22 kg I/O Expansion module – 0.11 kg
Terminal blocks connectors	0.2-1.5mm ² ; 16-26 AWG;
Environmental and Reliability	
MTTF	> 200,000 hours
Operation temperature	Commercial: 0° to 50° C
	Industrial: -40° to 70° C
Storage temperature	-40° to 85° C
Relative humidity	10% to 90% (operation)
	05% to 95% (storage)
Compliance	
Regulatory	FCC, CE, UKCA
EMC	EN 55032/5, EN 61000-6-2, EN 61000-6-3
Safety	EN/UL/IEC 62368-1

2.3 IOT-DIN-IMX8PLUS Part Number

To decode the IOT-DIN-IMX8PLUS part number please refer to the ‘Ordering’ section of the IOT-DIN-IMX8PLUS product page: <https://www.compulab.com/products/iot-gateways/iot-din-imx8plus-industrial-iot-gateway/#ordering>.

3 CORE SYSTEM COMPONENTS

3.1 NXP i.MX8M Plus SoC

The i.MX8M Plus processors feature advanced implementation of a quad ARM® Cortex®-A53 core, which operates at speeds of up to 1.8 GHz. A general purpose Cortex®-M7 core processor enables low-power processing.

Figure 1 i.MX8M Plus Block Diagram

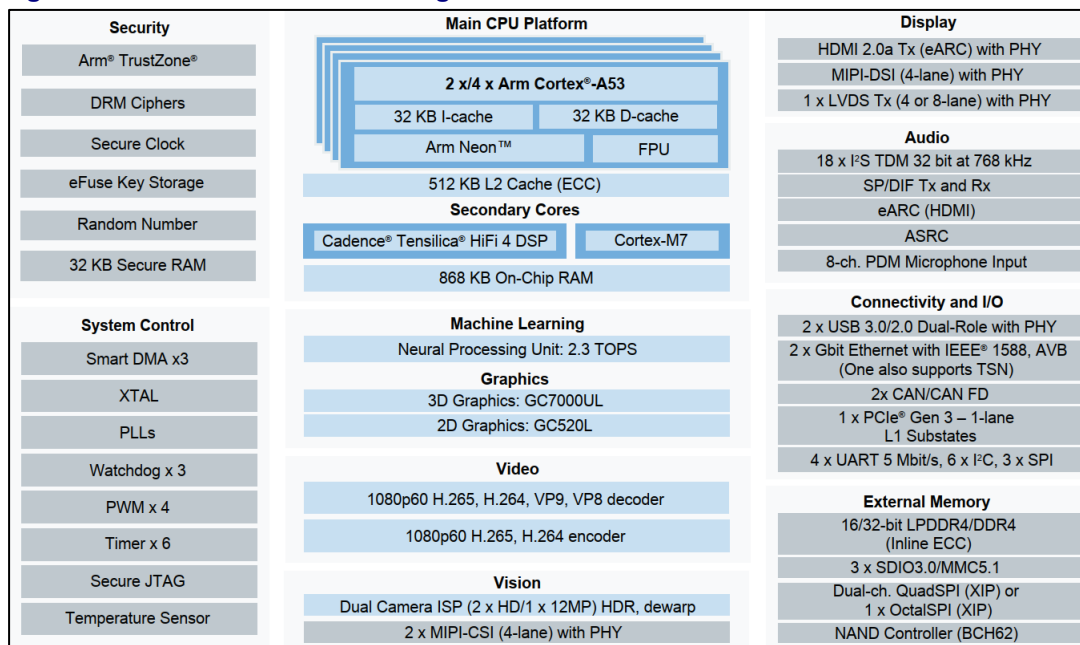

3.2 System Memory

3.2.1 DRAM

IOT-DIN-IMX8PLUS is available with up to 8GB of on-board LPDDR4 memory.

3.2.2 Primary Storage

IOT-DIN-IMX8PLUS features up to 128GB of soldered on-board eMMC memory for storing the bootloader and operating system (Kernel and root filesystem). The remaining eMMC space is used to store general-purpose (user) data.

3.3 Cellular and GPS

IOT-DIN-IMX8PLUS cellular interface is implemented with a mini-PCIe cellular modem module and a nano-SIM socket. To set up IOT-DIN-IMX8PLUS for cellular functionality, install an active SIM card into nano-SIM socket. The cellular module should be installed into the mini-PCIe socket.

The cellular modem module also implements GNSS / GPS.

A secure lock panel is protecting the SIM card from external unauthorized tampering or extraction.

Modem antenna connections are available via SMA connectors on the IOT-DIN-IMX8PLUS front panel. Compulab supplies IOT-DIN-IMX8PLUS with the Quectel EC25-G 4G/LTE CAT4 global cellular module.

Note: Cellular modem is present only in gateways ordered with the “JEG25G” configuration option

3.4 Ethernet

IOT-DIN-IMX8PLUS incorporates two independent Ethernet ports implemented with i.MX8M Plus internal MACs and two Realtek RTL8211 PHYs.

3.5 Serial Debug Console

IOT-DIN-IMX8PLUS features a serial debug console via a UART-to-USB bridge over micro USB connector. CP2104 UART-to-USB bridge is interfaced with i.MX8M Plus UART port. CP2104 USB signals are routed to micro USB connector on the front panel, labeled DBG.

3.6 USB Programming Port

IOT-DIN-IMX8PLUS features a USB SDP programming interface that can be used for device recovery using the NXP UUU utility.

USB programming interface is routed to the micro USB port located on the bottom of the device. The connector can be optionally protected from unauthorized access with a secure screw panel.

When a host PC is connected with a USB cable to the USB programming connector, IOT-DIN-IMX8PLUS disables normal boot from eMMC and enters Serial Downloader boot mode.

3.7 Industrial I/O Terminal Block

IOT-DIN-IMX8PLUS features a 16-pin terminal block containing several I/O interfaces. Each interface is galvanically isolated from the IOT-DIN-IMX8PLUS, and from each other.

For connector pin-out please refer to section 6.4.

3.7.1 CAN Bus

IOT-DIN-IMX8PLUS features a CAN 2.0B port implemented with i.MX8M Plus CAN controller. Key characteristics:

- Galvanic isolation from the main unit

Note: IOT-DIN-IMX8PLUS does NOT provide built-in termination on the CAN bus port. External termination should be added depending on the bus topology.

3.7.2 RS485

RS485 function is implemented with MAX13488 transceiver interfaced with i.MX8M Plus UART port. Key characteristics:

- 2-wire, half-duplex
- Galvanic isolation from the main unit
- Programmable baud rate of up to 3Mbps
- Optional 120Ω termination resistor

The integrated 120Ω termination resistor can be enabled by shorting between RS485_TRM (pin 9) to RS485_COM (pin 10).

3.7.3 RS232

RS232 function is implemented with MAX3221 (or compatible) transceiver interfaced with i.MX8M Plus UART port. Key characteristics:

- RX/TX only
- Galvanic isolation from the main unit
- Programmable baud rate up to 250kbps

3.7.4 Digital inputs (x2) and outputs (x2)

Two self-powered digital inputs are implemented with the CLT03 digital termination in accordance with EN 61131-2. The inputs are self-powered, meaning that an external power supply is not required for operation. Two digital outputs are implemented with the TPS272C dual channel high-side switch in accordance with EN 61131-2. Key characteristics:

- Designed for 24V PLC applications
- Galvanic isolation from main unit and other I/O modules
- Digital outputs maximal output current – 1A per channel
- Digital inputs self-powered with current limit

Table 5 Digital I/O Characteristics

Parameter	Description	Min	Typ.	Max	Unit
VDC	External power supply voltage	6	24	30	V
VIN _{TLH}	Low to High input voltage		9.4	11	V
VIN _{THL}	High to Low input voltage	5	7.5		V
VIN _{HYST}	Input trigger hysteresis	1.2		2.6	V
IOUT	Maximum output current per channel			1	A

Figure 2 Digital output – typical wiring example

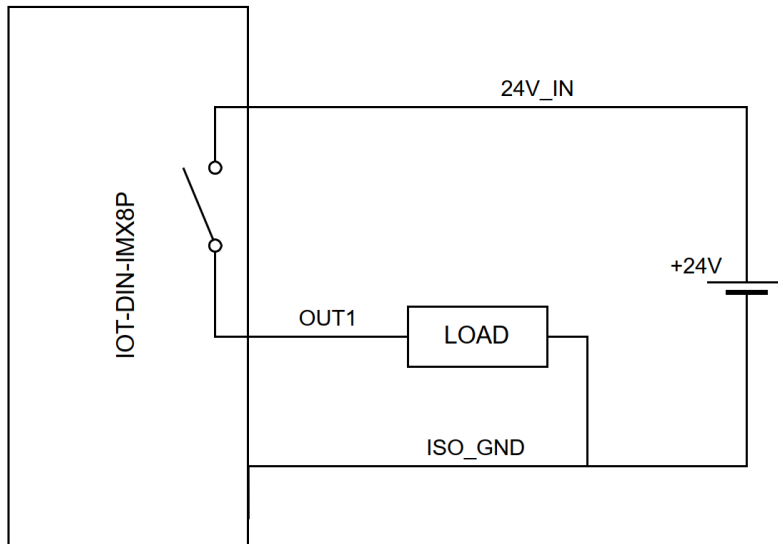
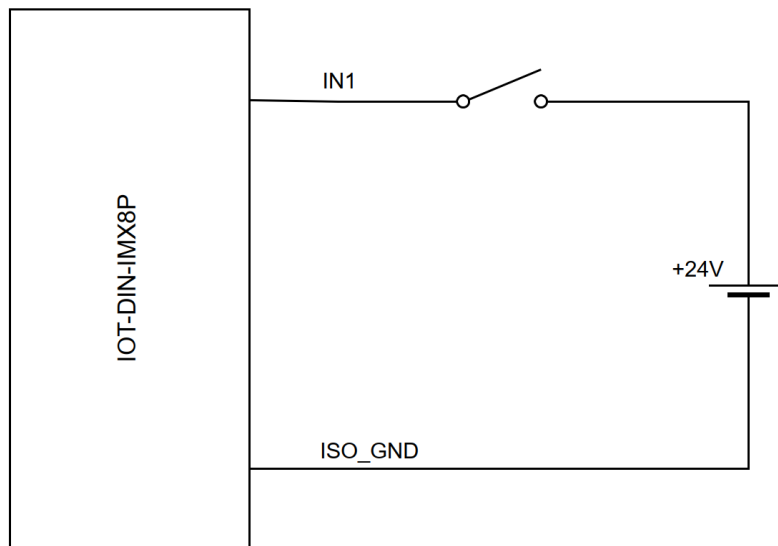

Figure 3 Digital input – typical wiring example



4 I/O EXPANSION MODULES

4.1 I/O Expansion Modules Interconnection

IOT-DIN-IMX8PLUS supports up to eight I/O Expansion Modules that can be stacked with the main gateway in order to extend the feature set of the system.

A gateway assembly includes one gateway (the left most unit) and multiple I/O Expansion modules. Module stacking is done from left to right. Up to 8 I/O Expansion Modules can be supported in one gateway assembly.

The modules are interconnected using Compulab's proprietary StackLink expansion connector that extends a series of the IOT-DIN-IMX8PLUS interfaces, creating a chain of peripherals.

Different I/O Expansion Modules utilize different I/O resources present in the StackLink interface. The following table outlines the resource requirements for each module type and the stacking restrictions.

Table 6 StackLink Interface Matrix

Module	Interface			
	PCIe	USB	I2CA	I2CB
IFM-DI8O8			x	
IFM-RS232		x		
IFM-RS485		x		
IFM-ADC8				x
IFM-WB	x	x		
Max. Modules:	1	3	4	1

NOTE: Modules using the PCIe interface must be installed in position A (next to the gateway)

4.2 Supported I/O Expansion Modules

Compulab supplied the following I/O Expansion Modules:

- IFM-RS485: 4x ports RS485 module
- IFM-RS232: 4x ports RS232 module
- IFM-DI8O8: 8x inputs + 8x outputs digital I/O module
- IFM-ADC8: 8x analog inputs module
- IFM-WB: WiFi / Bluetooth module

For detailed specification of I/O Expansion Modules please refer to the [I/O Expansion Modules reference guide](#).

5 SYSTEM LOGIC

5.1 Power Subsystem

5.1.1 Power Rails

IOT-DIN-IMX8PLUS is powered from a single power rail through the DC power connector.

5.1.2 Power Modes

IOT-DIN-IMX8PLUS supports three hardware power modes.

Table 7 Power modes

Power Mode	Description
ON	All internal power rails are enabled. Mode entered automatically when the main power supply is connected.
OFF	CPU core power rails are off. All peripheral power rails are off.
Sleep	DRAM is maintained in self-refresh. Most CPU core power rails are off. Most of the peripheral power rails are off.

5.1.3 RTC Back-Up Battery

IOT-DIN-IMX8PLUS features a 120mAh coin cell lithium battery, which maintains the on-board RTC whenever the main power supply is not present.

5.2 Real-Time Clock

IOT-DIN-IMX8PLUS RTC is implemented with the AM1805 real-time clock (RTC) chip. The RTC is connected to the i.MX8M Plus SoC using I2C interface at address 0xD2/D3. IOT-DIN-IMX8PLUS back-up battery keeps the RTC running to maintain clock and time information whenever the main power supply is not present.

5.3 Hardware Watchdog

IOT-DIN-IMX8PLUS watchdog function is implemented with the i.MX8M Plus watchdog.

5.4 Trusted Platform Module

IOT-DIN-IMX8PLUS is assembled with an Infineon SLB 9673 TPM2.0 compatible device.

6 INTERFACES AND CONNECTORS

6.1 Connector Locations

6.1.1 Front Panel

Item	Description	
1	System status indicator. Dual-color blue/amber LED	
2	USB 3.0 connector	
3	User programmable LED A & LED B	
4	User programmable recessed push-button	
5	Ethernet ports, dual RJ45 connector	
6	System reset push-button	
7	Console connector, micro-USB type	
8	Antenna A, SMA RP *	
9	Industrial I/O terminal block, 16 pin, 16-26 AWG	
10	Antenna B, SMA RP *	
11	DC power input connector	
	*: Present only in configuration with cellular modem	

6.1.2 Bottom Panel

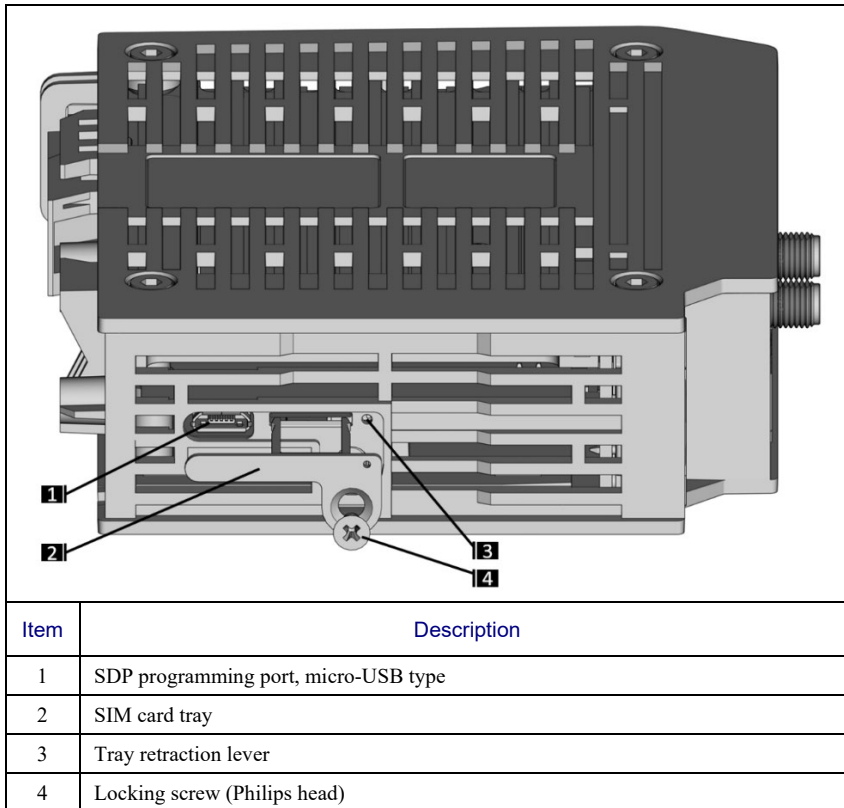

6.2 DC Power Connector

DC power input connector.

Table 8 Power connector pin-out

Pin	Signal Name	Description
1	+V	V+ DC pin (for wire 16-20 AWG)
2	V-	V0 DC pin (for wire 16-20 AWG)
3	CNTL	Programmable power control
4	P.E.	Protective Earth connection

Table 9 Power connector data

Connector type	Pin numbering
4-pin dual-row plug with screw terminal connections Locking: screw flange Pitch: 3.5 mm Wire cross-section: AWG 16 – AWG 26 Connector P/N: JL15EDGVM-35004G0[1 2] Mating connector P/N: JiNL JL15EDGKM-35004G01 NOTE: Compulab supplies the mating connector with the gateway unit	

6.2.1 Remote Power CNTL Input

A remote power button can be connected to the DC input terminal block of the device. Pressing the button changes the power state of the system. Connect the button between the CNTL pin on the power input terminal block the system 0V (V-).

Table 10 Power Button Control

Current State	Press	Resulting State
ON	Short	OFF (O/S controlled shutdown)
ON	Long	OFF (forced hardware shutdown)
OFF	Short	ON

**Warning: Connecting the Remote Power Button input to DC voltage may damage the device.
 *** Only connect the input pin to GND via contact switch *****

6.2.2 Typical Connection Schematic

Figure 4 power connector typical connection

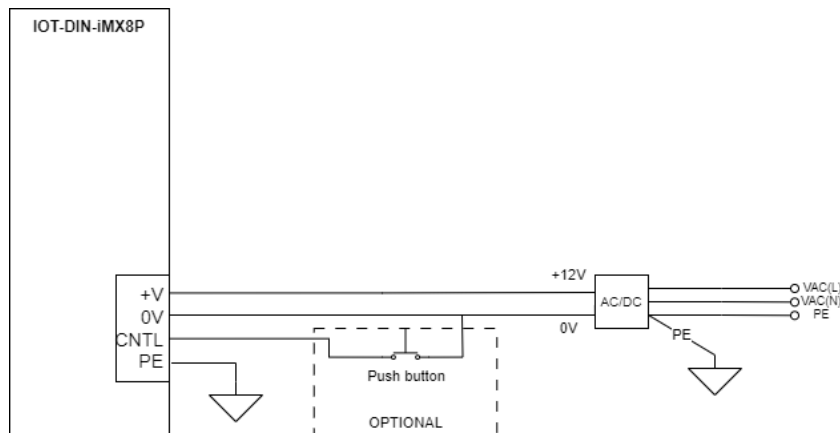

6.3 USB Host Connector

IOT-DIN-IMX8PLUS USB3.0 host port is available through standard type-A USB3 connector. USB3.0 port is implemented directly with the native i.MX8M Plus port.

6.4 Industrial I/O Connector

IOT-DIN-IMX8PLUS industrial I/O signals are routed to terminal block. Connector pin-out is shown below. For additional details please refer to section 3.7.

Table 11 Industrial I/O add-on connector pin-out

Pin	Signal Name	Description	Isolation Power Domain
1	DIO_VIN	Digital I/O external DC power input	DIO
2	DIO_IN0	Digital input 0	DIO
3	DIO_OUT0	Digital output 0	DIO
4	DIO_IN1	Digital input 1	DIO
5	DIO_OUT1	Digital output 1	DIO
6	DIO_COM	Digital I/O isolated ground	DIO
7	RS485_D-	RS485 negative	RS485
8	RS485_D+	RS485 positive	RS485
9	RS485_TRM	RS485 termination control	RS485
10	RS485_COM	RS485 isoalted ground	RS485
11	RS232_RxD	RS232 receive	RS232
12	RS232_TxD	RS232 trasmit	RS232
13	CAN_COM	CAN isolated ground	CAN
14	RS232_COM	RS232 isolated ground	RS232
15	CAN_L	CAN bus low	CAN
16	CAN_H	CAN bus high	CAN

Table 12 Industrial I/O add-on connector data

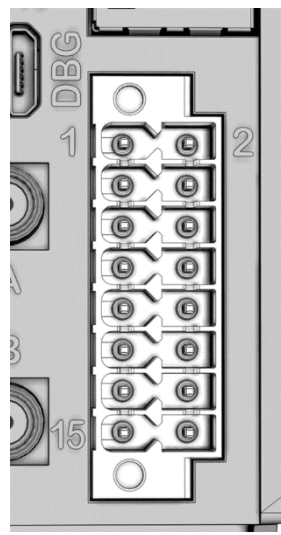
Connector type	Pin numbering
<p>16-pin dual-row plug with push-in spring connections Locking: screw flange Pitch: 3.5 mm Wire cross-section: AWG 16 – AWG 26</p> <p>Connector P/N: JiLN JL15EDGRHCM-35005B01 Mating connector P/N: JiLN JL15EDGKNHM-35016B01</p> <p>NOTE: Compulab supplies the mating connector with the gateway unit</p>	

6.5 Serial Debug Console

IOT-DIN-IMX8PLUS serial debug console interface is routed to micro USB connector. For additional information, please refer to section 3.6 of this documents.

6.6 RJ45 Ethernet Connectors

IOT-DIN-IMX8PLUS features two Ethernet ports ETH0 and ETH1, routed to two RJ45 connectors. For more info, refer to section 3.4.

6.7 SIM card socket

IOT-DIN-IMX8PLUS nano-SIM card socket is located on the bottom panel.

For SIM card installation instructions please refer to the IOT-DIN-IMX8PLUS User's Manual.

6.8 Indicator LEDs

The tables below describe IOT-DIN-IMX8PLUS indicator LEDs.

Table 13 System Status LED

LED State	Gateway Status
OFF	System is in OFF or deep-sleep state
Solid BLUE	System is running U-boot bootloader
Solid PURPLE	U-boot bootloader is not running. Indicates bootloader corruption
Blinking BLUE	System is running Linux O/S. Normal operation mode
Blinking AMBER	Invalid combination of I/O expansion modules detected

General purpose LEDs are active high and controlled by SoC GPIOs.

Table 14 User LED A

GPIO	LED
GPIO5_2	Green
GPIO5_4	Red

Table 15 User LED B

GPIO	LED
GPIO5_1	Green
GPIO5_3	Red

6.9 Antenna Connectors

IOT-DIN-IMX8PLUS features two SMA connectors for external antennas.

Table 16 Default antenna connector assignment

Connector Name	Function	Connector Type
A	LTE main antenna	SMA
B	GPS antenna	SMA

NOTE: SMA connectors are present only in gateway configurations with cellular modem

7 MECHANICAL DRAWINGS

IOT-DIN-IMX8PLUS 3D model is available for download at:

<https://www.compulab.com/products/iot-gateways/iot-din-imx8plus-industrial-iot-gateway/#devres>

8 OPERATIONAL CHARACTERISTICS

8.1 Absolute Maximum Ratings

Table 17 Absolute Maximum Ratings

Parameter	Min	Max	Unit
Main power supply voltage	-0.3	32	V

NOTE: Stress beyond Absolute Maximum Ratings may cause permanent damage to the device

8.2 Recommended Operating Conditions

Table 18 Recommended Operating Conditions

Parameter	Min	Typ.	Max	Unit
Main power supply voltage	9.6	12-24	28.8	V

8.3 Typical Power Consumption

*** To be included in future revisions of this document